

DURO-T



APPLICATION

Optimized for turning applications, which require extremely high clamping forces, maximum concentricity, as well as reliable long-term repeatability. In combination with a base plate, stationary use on milling machines, dividing units and machining centers.

TYPE

Key bar chuck with quick-action jaw change system. Guaranteed maximum jaw precision as far as these are only used on the same chuck, and base and top jaws are kept screwed on for recurring work.

CUSTOMER BENEFITS

- ⊕ Maximum clamping force thanks to key bar system
- ⊕ Concentricity and axial run-out tolerance twice as exact as required in DIN precision class 1
- ⊕ Very high jaw-change repeatability
- ⊕ Balanced and jaws in chuck ground out for concentricity

TECHNICAL FEATURES

- With jaw safeguard
- Chuck body completely surface-hardened
- Visual marking for quick jaw adjustment
- External shape incl. splash-water edge
- Fastening options for strongly stressed sliding surfaces
- Incl. safety key
- High corrosion protection

A08
Cylindrical centre mount

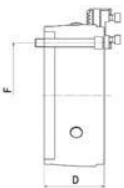

Size	Inch	Through-hole mm	With one-piece reversible jaws	With base jaws and reversible top jaws	D mm	Speed max. min ⁻¹	Max. Torque Nm	Max. total clamping force kN
125	5	32	437475	-	46,5	6000	40	23
160	6 1/4	42	437476	437490	63	5400	120	73
200	8	52	437477	437491	81	4600	155	114
250	10	62	437478	437492	92	4200	190	185
315	12 1/2	87	437479	437493	111	3300	210	240
400	15 3/4	102	437480	437494	118	2200	260	260
500	20	162	437481	437495	118	1900	320	290
630	25	252	-	437496	143	1100	350	320

1) at size 630 chuck body without convex outer contours
Further sizes and mountings available on request

A08
ISO 702-3 (DIN 55027), with studs and locknuts

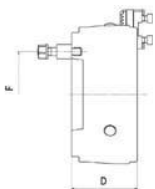

Size	Mount short taper	Through-hole mm	With one-piece reversible jaws	With base jaws and reversible top jaws	D mm	F mm	Speed max. min ⁻¹	Max. Torque Nm	Max. total clamping force kN
125	5	32	437499	-	67	104,8	6000	40	23
160	5	42	437501	437548	78	104,8	5400	120	73
160	6	42	437502	437549	85	133,4	5400	120	73
200	5	52	437504	437551	96	104,8	4600	155	114
200	6	52	437505	437552	97	133,4	4600	155	114
250	6	62	437509	437556	108	133,4	4200	190	185
250	8	62	437510	437557	110	171,4	4200	190	185
315	8	87	437512	437559	129	171,4	3300	210	240
315	11	87	437513	437560	131	235	3300	210	240
400	8	102	437515 ▲	437562 ▲	138	171,4	2200	260	260
400	11	102	437516 ▲	437563 ▲	138	235	2200	260	260
500	11	162	437519 ▲	437566 ▲	156	235	1900	320	290
500	15	162	437520 ▲	437567 ▲	163	330,2	1900	320	290
630	11	192	-	437568 ▲	165	235	1100	350	320
630	15	252	-	437569 ▲	167	330,2	1100	350	320

1) at size 630 chuck body without convex outer contours
Further sizes and mountings available on request

Jaws DURO-T

A28

One-piece jaw EB, set, diagonally toothing, hardened



Item no.	Chuck Size	Contents of delivery	Jaw length	Jaw height	Jaw width
212121	125	set	50	34	14
094000	160	set	77,7	45	20
094001	200	set	94,7	60	22
094002	250	set	114	70	26
094003	315	set	130	79	32
094043	400/500	set	167	93	45

Additionally or later purchased, hardened jaws must be ground out in the chuck.
For jaws which are applied later, send in the chuck.

Jaws DURO-T

A28

Unstepped Jaw BL, set, diagonally toothing, unstepped, soft, material 16MnCr5



Item no.	Chuck Size	Contents of delivery	Jaw length	Jaw height	Jaw width
304864	125	set	53	34	14
241699	160	set	84,4	45	20
249678	200	set	98,4	60	22
249679	250	set	118,7	70	26
249680	315	set	136,6	79	32
249681	400/500	set	173,6	93	45

A28

Reversible top jaw UB, set, hardened



Item no.	Chuck Size	Contents of delivery	Jaw length	Jaw height	Jaw width
094012	160	set	61,5	32,5	20,4
094013	200	set	70,5	38	24,4
094014	250	set	92	50	34,4
094015	315	set	107	56	35,7
094045	400/500	set	130	72	50,4
140715	630	Satz	185	102	68

Additionally or later purchased, hardened jaws must be ground out in the chuck.
For jaws which are applied later, send in the chuck.

A28

Unstepped top jaw AB, set, standard design, soft, material 16MnCr5



Item no.	Chuck Size	Contents of delivery	Jaw length	Jaw height	Jaw width
212123	125	set	55	25,5	20,7
094008	160	set	85	36,5	20,3
094009	200	set	105	40	22
094010	250	set	125	50	30,4
094011	315	set	145	50	34,3
094046	400/500	set	180	73	50,5
140716	630	set	260	102	68

A28

Unstepped top jaw AB, set, extendend design, soft, material 16MnCr5



Item no.	Chuck Size	Contents of delivery	Jaw length	Jaw height	Jaw width
137055	160	set	85	42,5	24,4
137056	200	set	105	51	34,3
137057	250	set	125	75	50,5
137058	315	set	145	74	50,5

Configure your individual clamping jaws online! www.web2product.biz

Jaws DURO-T

A28
Base jaw GB, set, diagonally toothing, with mounting bolts



Item no.	Chuck Size	Contents of delivery	Jaw length	Jaw width
212119	125	set	47	14
094004	160	set	74	20
094005	200	set	90	22
094006	250	set	110	26
094007	315	set	125	32
094044	400/500	set	160	45
140194	630	set	230	65

C 21
Reversible claw-type top jaws, standard design, tongue and groove, large clamping range, 1 piece hardened



Item no.	Chuck Size	Jaw length	Jaw height	Jaw width
137060	160	66	37,5	24
137119	400/500	124	62	50
151289	630	144	78	70

C 21
Reversible claw-type top jaws, standard design, tongue and groove, small clamping range, 1 piece, hardened



Item no.	Chuck Size	Jaw length	Jaw height	Jaw width
137061	160	66	37,5	20
137064	200	81	43	24
137108	250	90	55	34
137114	315	100	62	34
137120	400/500	124	62	50

C 21
Reversible claw-type top jaws, standard design, tongue and groove, middle sized clamping range, 1 piece, hardened



Item no.	Chuck Size	Jaw length	Jaw height	Jaw width
137062	160	56	37,5	20
137065	200	66	43	24
137109	250	72	55	34
137115	315	86	62	34
137121	400/500	100	62	50

C 21
Reversible claw-type top jaws, large design, tongue and groove, small clamping range, 1 piece hardened



Item no.	Chuck Size	Jaw length	Jaw height	Jaw width
137066	160/200	79	43	34
137110	250	80	55	50
137116	315	93	62	50

Configure your individual clamping jaws online! www.web2product.biz

Jaws DURO-T

Jaws DURO-T

C 21

Reversible claw-type top jaws, large design, tongue and groove, large clamping range, 1 piece, hardened



Item no.	Chuck Size	Jaw length	Jaw height	Jaw width
137067	160/200	81	43	34
137111	250	90	55	50
137117	315	106	62	50

C 21

Reversible claw-type top jaws, large design, tongue and groove, middle sized clamping range, 1 piece, hardened



Item no.	Chuck Size	Jaw length	Jaw height	Jaw width
137068	160/200	66	43	34
137112	250	72	55	50
137118	315	86	62	50

C 21

Draw-down jaws, without clamping inserts, diagonally toothing, 1 piece, without clamping inserts



Item no.	Chuck Size	Jaw length	Jaw height	Jaw width
141037	160	84,4	43,5	20
141039	200	98,4	47,5	22
141041	250	118,7	58,5	26
141043	315	136,4	63,9	32
141045	400/500	173,6	73,4	45

C 21

Draw-down jaws, additional clamping range, for interchangeable clamping inserts, diagonally toothing, 1 piece, without clamping inserts



Item no.	Chuck Size	Jaw length	Jaw height	Jaw width
141038	160	84,4	43,5	20
141040	200	98,4	47,5	22
141042	250	118,7	58,5	26
141044	315	136,4	63,9	32
141046	400	173,6	73,4	45
141048	500	173,6	73,4	45

Jaws DURO-T

C 15
Interchangeable clamping inserts, 1 piece with claws



Item no.	Chuck Size
141049	160/200
141052	250/315
141055	400/500/630

C 15
Interchangeable clamping inserts, 1 piece with serrated toothing



Item no.	Chuck Size
141050	160/200
141053	250/315
141056	400/500

C 15
Interchangeable clamping inserts, 1 piece with heat treatable surface



Item no.	Chuck Size
141051	160/200
141054	250/315
141057	400/500

C15
Jaw mounting bolt, piece



Item no.	Size	Thread	Contents of delivery
243893	125	M6x10	piece
200182	160/200	M8x1x22	piece
200183	250	M12x1,5x30	piece
202402	315	M12x1,5x35	piece
227618	400/500	M16x1,5x40	piece
249388	630	M20x50	piece

Jaws DURO-T

Accessories DURO-T

Accessories DURO-T

A08

Base plate with fixing slots

Complete with mounting screws and fixed T-slot nuts. Other sizes available on request.



Item no.	Size
143163	160
143165	200
143167	250

A08

Key



Item no.	Size	Square	L mm
212124	125	8	85
094016	160	10	140
094017	200	12	160
094018	250	14	220
094019	315	17	230
094047	500	19	250
332938	630	24	410

Only for stationary used chucks

A08

Safety key



Item no.	Size	Square	L mm
242172	125	8	85
242173	160	10	140
242174	200	12	160
242175	250	14	220
242176	315	17	230
242177	500	19	250
332939	630	24	410

corresponding with DIN 1550 for rotating chucks

A08

Chip guard, set



Item no.	Size	Contents of delivery
212122	125	set
236439	160	set
236440	200	set
236441	250	set
236442	315	set
236443	500	set

C15

Special grease F80 for lathe chucks

For lubrication and conservation of chucking power



Item no.	Design	Contents
308555	Cartridge	0,5 kg
028975	Tin	1 kg

Technical Data DURO-T

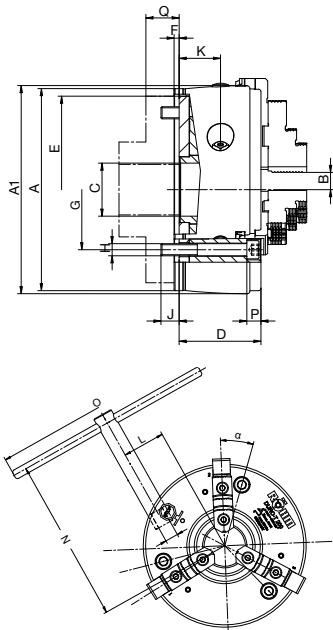

Chuck size A		125	160	200	250	315	400	500	630
Outer diameter	A1	128	164	206	256	322	407	507	630
Jaw movement	B	4,8	6,2	6,8	8	10,2	12,5	12,5	14
Bore	C	32	42	52	62	87	102	162	252
Bore can be enlarged	C max.	35	45	55	75	102	130	180	270
	D	46,5	63	81	92	111	118	118	143
	EH6	115	145	185	235	300	380	460	580
	F	4	5	5	6	6	6	6	6
	G	100	125	160	200	250	315	400	520
	H	3xM8	3xM10	3xM12	3xM16	3xM20	3xM24	3xM24	3xM24
	J	12	15	18	25	30	37	37	37
	K	22,5	31,5	43	47	59	57,7	57,5	72
	L	32,5	42	53,5	66,5	86	110	152,5	196
	M	SW8	SW10	SW12	SW14	SW17	SW19	SW19	SW24
	N	117	182	211	284	309	359	356	570
	O	180	210	270	450	500	600	600	600
	P	8,5	13	14	17	21	25	25	29
	Q	17	30	30	35	35	40	45	55
Min. thickness of flange									
Moment of inertia GD2 ¹⁾	kgm ²	0,01	0,03	0,10	0,29	0,87	2,37	5,78	17,04
	α	21° 35'	22°	18°	19°	17°	20°	42°	69° 30'
approx. kg	kg	4,0	9,3	18,6	34,5	64	112	166	300

1) The moment of inertia was measured with base jaws but without top jaws or back plate

The bore could be enlarged (measure C, at surcharge)

■ Enlarged bore max.

Technical Data
DURO-T

Max. permissible speed

The maximum permissible speed has been fixed so that 1/3 of the gripping force is still available as residual gripping force if the maximum gripping is applied and the chuck is fitted with its heaviest jaws. The jaws may not project beyond the outside diameter of the chuck. The chuck must be in perfect condition. The specification DIN 6386 Part 1 shall be observed.

Chuck size		125	160	200	250	315	400	500	630
Max. speed	min ⁻¹	6000	5400	4600	4200	3300	2200	1900	1100

Gripping force

The gripping force is the sum total of all jaw forces acting radially on the stationary workpiece.

The specified gripping forces are standard values.

They apply to chucks in a perfect condition which have been lubricated with RÖHM grease F79 and F80.

Chuck size		125	160	200	250	315	400	500	630
Torque applied on key 1)	Nm	10	40	60	70	80	90	100	100
Total gripping force 1)	kN	8,5	30	48	66	80	95	102	102
Torque applied on key	Nm	40	120	155	190	210	260	320	350
Max. total gripping force	kN	23	73	114	185	240	260	290	320

1) maintaining the accuracy

At this torque the clamping jaws have been ground at the factory, for testing the chuck must be clamped with this torque

Chuck capacities of jaw steps

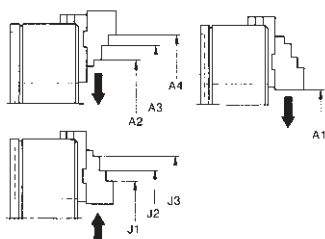

Chuck size		125	160	200	250	315	400	500	630	
External chucking	Jaw position	A1	3-30	5-51	7-70	8-97	12-131	16-168	40-256	20-322
		A2	31-65	45-91	58-123	82-172	93-216	119-278	167-360	200-490
		A3	63-97	89-135	114-179	-	-	-	-	-
		A4	95-129	115-161	142-207	163-253	201-323	260-413	308-501	360-650
Internal chucking	Jaw position	J1	26-59	67-105	71-131	99-182	102-213	120-272	166-360	184-489
		J2	57-91	93-132	99-159	-	-	-	-	-
		J3	89-123	135-174	154-214	178-261	207-319	260-412	306-500	341-646

Jaw dimensions DURO-T

Reversible one-piece jaw **EB**, hardened and ground, jaw steps not ground

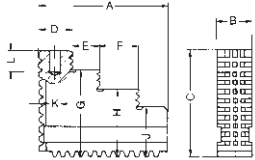

Block jaw **BL**, unstepped, soft, thread and jaw guides hardened and ground

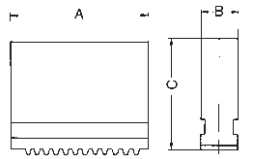

Chuck size	125	160	200	250	315	400+500
A	50	77,7	94,7	114	130	167
B	14	20	22	26	32	45
C	34	45	60	70	79	93
D	10,7	20,6	23	41,5	40,2	50,5
E	16	18,9	19,5	40,3	54	71
F	16	22	28	-	-	-
G	29	37,5	50	56	64	73
H	24	30	40	-	-	-
J	19	22,5	30	42	49	53
K	-	8	10	13	13	20
L	-	16	15	19,5	19,5	30
Jaw approx. kg	0,400	0,500	0,635	1,135	1,835	3,665

Chuck size	125	160	200	250	315	400+500
A	53	84,4	98,4	118,7	136,6	173,6
B	14	20	22	26	32	45
C	34	45	60	70	79	93
Jaw approx. kg	0,435	0,500	0,900	1,535	2,400	5

Reversible top jaw **UB**, completely hardened, cross tenon ground, jaw steps not ground

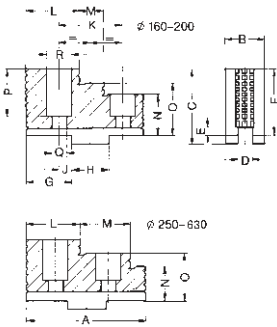

Chuck size	160	200	250	315	400+500	630
A	61,5	70,5	92	107	130	185
B	20,4	24,4	34,4	35,7	50,4	68
C	37	43	55	62	79	110
D	8	10	12	12	18	24
E	3	3,5	3,5	3,5	4,5	4,5
F	32,5	38	50	56	72	102
G	22,5	25,5	30	35,5	41,4	59
H	18	20	20	26	30	40
J	7	10	10	14	15	21
K	32	40	40	54	60	82
L	26,5	28,5	41	40	51	80
M	13	14	40,5	54	71	80
N	17,5	18	22	26	32	42
O	25	28	36	41	52	72
P	23,5	29	39	40	57	82
Q	9	9	14	14	18	22
R	15	15	20	20	26	33
T ¹⁾	38,5	45	57	63,6	80,6	114
Jaw approx. kg	0,200	0,335	0,800	1,135	2,535	6,350

1) Dimension marked on base jaw

Unstepped soft top jaw **AB**, for turning out special chucking diameters

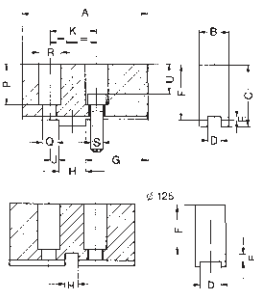

Dimensions for extendend design

Chuck size	125	160	200	250	315	400+500	630				
A	55	85	85	105	105	125	125	145	145	180	260
B	20,7	20,3	24,4	22	34,3	30,4	50,5	34,3	50,5	50,5	68
C	31,3	41	47	45	56	55	80	56	80	80	110
D	14	8	8	10	10	12	12	12	12	18	24
E	3,3	3	3	3,5	3,5	3,5	3,5	3,5	3,5	4,5	4,5
F	25,5	36,5	42,5	40	51	50	75	50	74	73	102
G	25	42	42	50	50	70	70	74	74	100	150
H	5	18	18	20	20	20	20	26	26	30	40
J	7,5	7	7	10	10	10	10	14	14	15	21
K	20	32	32	40	40	40	40	54	54	60	82
P	24	27,5	33,5	31	42	39	54	34	48	58	83
Q	6,5	9	9	9	9	14	14	14	14	18	22
R	11	15	15	15	15	20	20	20	20	26	33
S	M6	M8x1	M8x1	M8x1	M8x1	M12x1,5	M12x1,5	M12x1,5	M12x1,5	M16x1,5	M20
T ¹⁾	32	42,5	48,5	47	58	57	72	57,6	71,6	81,6	114
U	18	19,5	25,5	23	34	27	42	22	36	42	63
Jaw approx. kg	0,200	0,435	0,600	0,735	1,400	1,500	3,700	2,265	4,800	4,500	13,350

1) Dimension marked on base jaw

Base jaws **GB**, hardened and ground

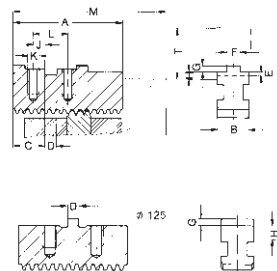

Chuck size	125	160	200	250	315	400+500	630
A	47	74	90	110	125	160	230
B	14	20	22	26	32	45	65
C	21	19	23	26	30	35	52
D	5	18	20	20	26	30	40
E	-	5	5,5	5,5	6,5	7,5	9
F	-	8	10	12	12	18	24
G	2,8	2,5	3	3	3	4	4
H	3,55	6	7	7	7,6	8,6	12
J	7,5	7	10	10	14	15	21
K	M6	M8x1	M8x1	M12x1,5	M12x1,5	M16x1,5	M20
L	20	32	40	40	54	60	82
M	72	103	129	163	196	250	399
Jaw approx. kg	0,200	0,265	0,365	0,700	1,065	2,350	5,665

Chucking capacities DURO-T

Reversible claw-type top jaws
KB, standard design

Reversible claw-type top jaw, large clamping range				
Chuck size	160	400	500	630
Item no.	137060	137119	137119	151289
Capacities external Ø min. - max.	142,5 - 187,5	314 - 446	311 - 534	391 - 670
Capacities internal Ø min. - max.	22,5 - 67,5	99 - 231	95 - 317	176 - 456
Interfering contour	224	528	592	800

Reversible claw-type top jaw, small clamping range						
Chuck size	160	200	250	315	400	500
Item no.	137061	137064	137108	137114	137120	137120
Capacities external Ø min. - max.	37,5 - 82,5	56 - 116	90 - 170	82 - 210	142 - 274	139 - 360
Capacities internal Ø min. - max.	133 - 178	160 - 220	177 - 257	242 - 370	301 - 433	266 - 488
Interfering contour	209	264	330	446	535	592

Reversible claw-type top jaw, medium clamping range						
Chuck size	160	200	250	315	400	500
Item no.	136062	137065	137109	137115	137121	137121
Capacities external Ø min. - max.	103 - 148	117 - 181	167 - 248	178 - 306	270 - 402	267 - 489
Capacities internal Ø min. - max.	71 - 116	91 - 155	100 - 184	97 - 225	142 - 274	139 - 361
Interfering contour	209	264	330	396	504	592