

# Automatic clamping units and draw bar extension



### APPLICATION

Actuation unit for HSK clamping systems.

### TYPE

Spring-actuated clamping unit.  
Individually adapted draw bar extension.

### CUSTOMER BENEFITS

- ⊕ Energy stored in the spring package
- ⊕ Slender design
- ⊕ Reliable function due to sturdy design

### TECHNICAL FEATURES

- Clamping system is designed individually for the spindle

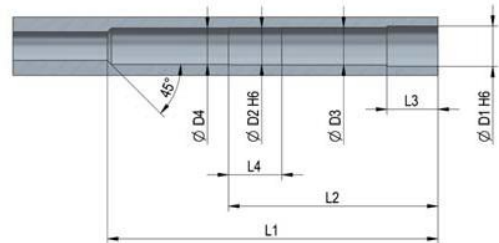
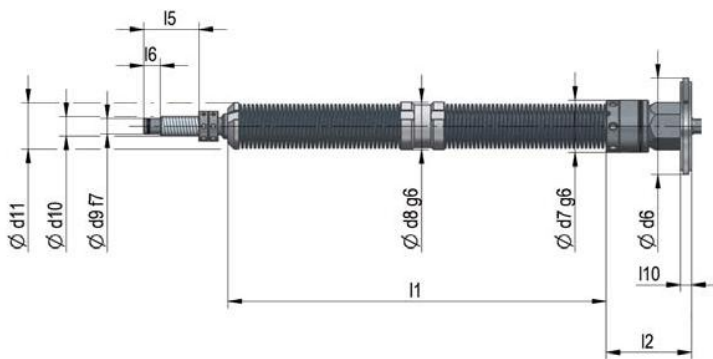

C 15  
HSK-clamping system with stationary release unit

Clamping unit HSK	32	40	50	63	80	100
d7	20	25	35	38	42	50
d8	18,5	22,5	30	35	38	42,5
d9	6,5	8,5	10	11	13	14,5
d10	M8x1	M10x1	M12x1,5	M14x1,5	M16x1,5	M18x1,5
d11	18	21,5	29	34	37	41,5
D1	20	25	35	38	42	50
D2	18,5	22,5	30	35	38	42,5
D3	19	23	30,5	35,4	38,5	43
D4	18,5	22	29,5	34,5	37,5	42,5
l1	150	190	225	274	282	350
l2	52	50	60	61,8	74	90
l5	22	26	32	40	40	45
l6	8	9	10	12	13	15
l10	8	8	8	8	8	8
L1	190	240	270	311	325	396
L2	115	150	180	197	210	250
L3	34	40	48	48	56	70
L4	38	42	50	50	58	65
Pull-in-force kN	5	10	15	25	35	50
Total stroke	9	13	15	16	18	20

Individual clamping systems available on request