

Pro - cylindrical shank

Live centres

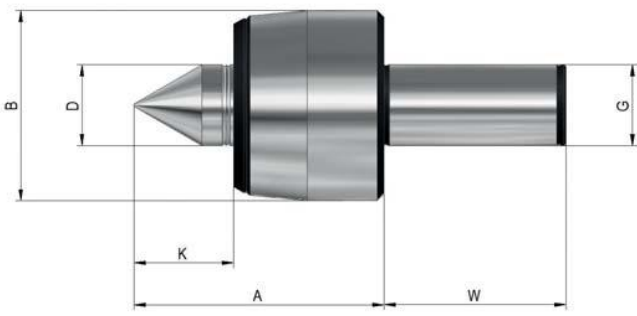

APPLICATION

For the counter-clamping of workpieces on turning and grinding machines using rotary chucks, collet chucks and tool take-ups. Take-up for tool magazine / turret.

TYPE

All-round live centre with cylindrical shank.

CUSTOMER BENEFITS

- ⊕ Proven 3-fold bearing for high axial and radial load
- ⊕ Lifetime lubrication for minimum required maintenance
- ⊕ Maximum concentricity deviation of 0.005 mm for maximum precision

TECHNICAL FEATURES

- Body hardened and ground
- Tip angle 60°

Note:

Live centres with cylindrical shank and clamping surface on request

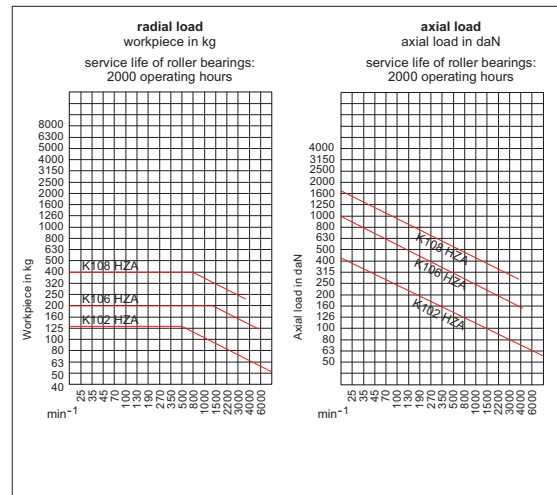

A06
HZA Pro with cylindrical shank, body hardened and ground - tip angle 60°

Item no.	1316054	1316055	1316056
Mount MT	ZA20	ZA25	ZA32
Size	102	106	108
A mm	58	76,8	93,1
B mm	43	48,5	68,5
D mm	20	25	32
G mm	20	25	32
K mm	24	30,5	40
Weight approx. g	414	891	1474
Workpiece weight max. kg	130	200	400
Concentricity deviation max. mm	0,005	0,005	0,005
Speed max. min ⁻¹	7000	5000	3800
Spare live centres	1241725	1241723	1241722