

RPP-50



APPLICATION

Universal gripping of round and angular workpieces with two parallel gripper fingers for handling with robots or portals.

TYPE

Available from sizes 50 to 380, each in two stroke variants. Optionally with gripping force safety device and/or dirt cover.

Fastening of the gripper fingers via centering sleeves (included in the scope of delivery).

CUSTOMER BENEFITS

- ⊕ High gripping force with low dead weight and compact design
- ⊕ High torque support for using long gripper fingers thanks to elongated jaw guide
- ⊕ Maximum flexibility thanks to versatile connection and fastening options
- ⊕ Long service life and high reliability thanks to specially ground base jaws in proven T-slot guide

TECHNICAL FEATURES

- Centrally clamping in compact design made of high-strength, hard-coated aluminum alloy
- All functional parts made of hardened steel for maximum service life
- Wedge hook principle with pneumatic actuation (hydraulic actuation available on request)
- Position monitoring with inductive or magnetic position sensors
- Optionally available with FKM seals for higher temperatures up to 150°C (on request)
- Integrated purge air connection to prevent contamination

C40

RPP-50 - 2-jaw parallel gripper air operated

Item no.	170119	170120 ▲	170121	170122 ▲	170123 ▲	170124 ▲
Design	RPP-50-1	RPP-50-2	RPP-50-1/GA	RPP-50-2/GA	RPP-50-1/GI	RPP-50-2/GI
Gripping force at 6 bar N	208	398	242	462	264	505
Stroke per jaw mm	4	2	4	2	4	2
Gripping force maintained N	-	-	35	65	35	65
Recommended workpiece weight kg	0,7	1,45	0,7	1,45	0,7	1,45
Weight kg	0,19	0,19	0,23	0,23	0,23	0,23
Width mm	65	65	65	65	65	65
Height mm	31	31	47	47	47	47
Depth mm	30	30	30	30	30	30
Mx Nm	20	20	20	20	20	20
My Nm	25	25	25	25	25	25
Mz Nm	10	10	10	10	10	10
Fz N	500	500	500	500	500	500
Operating pressure min./max. without GA/GI bar	2-8	2-8	-	-	-	-
Operating pressure min./max. with GA/GI bar	-	-	4-7	4-7	4-7	4-7
Clamping time s	0,02	0,02	0,02	0,02	0,03	0,03
Opening time s	0,02	0,02	0,03	0,03	0,02	0,02
Air consumption per cycle cm ³	5	5	5	5	5	5
Max. allowable length of jaw mm	64	64	64	64	64	64

RPP-50

Max. load on gripper and jaw

Clamping force diagram exterior gripping

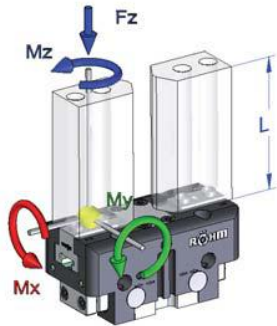

Total gripping force F(N) at 6 bar

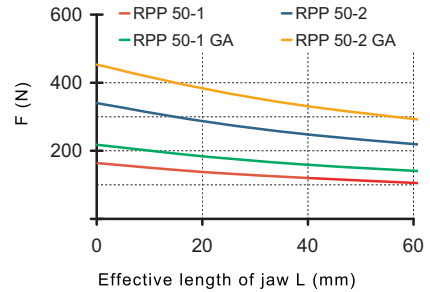

RPP 50-1: 3,05
RPP 50-2: 4,05

RPP 50-1: 18,8
RPP 50-2: 20,8

RPP 50-1 MAX. 33,5 ; MIN. 25,5
RPP 50-2 MAX. 31,5 ; MIN. 27,5

Tubeless direct connection

T-nut for distance measurement

Sensor holder Ø 3 (2x)

C-nut for magnetic sensors

Section A-A

Sleeve Ø6 for gripper connection

Type GA/GI with gripping force safety device

Accessories: Protective cover

Parallel gripper RPP

RPP-64



APPLICATION

Universal gripping of round and angular workpieces with two parallel gripper fingers for handling with robots or portals.

TYPE

Available from sizes 50 to 380, each in two stroke variants. Optionally with gripping force safety device and/or dirt cover. Fastening of the gripper fingers via centering sleeves (included in the scope of delivery).

CUSTOMER BENEFITS

- ⊕ High gripping force with low dead weight and compact design
- ⊕ High torque support for using long gripper fingers thanks to elongated jaw guide
- ⊕ Maximum flexibility thanks to versatile connection and fastening options
- ⊕ Long service life and high reliability thanks to specially ground base jaws in proven T-slot guide

TECHNICAL FEATURES

- Centrally clamping in compact design made of high-strength, hard-coated aluminum alloy
- All functional parts made of hardened steel for maximum service life
- Wedge hook principle with pneumatic actuation (hydraulic actuation available on request)
- Position monitoring with inductive or magnetic position sensors
- Optionally available with FKM seals for higher temperatures up to 150°C (on request)
- Integrated purge air connection to prevent contamination

C40

RPP-64 - 2-jaw parallel gripper air operated

Item no.	170001	170002 ▲	170003	170004 ▲	170005 ▲	170006 ▲
Design	RPP-64-1	RPP-64-2	RPP-64-1/GA	RPP-64-2/GA	RPP-64-1/GI	RPP-64-2/GI
Gripping force at 6 bar N	316	605	458	876	487	932
Stroke per jaw mm	6	3	6	3	6	3
Gripping force maintained N	-	-	100	200	100	200
Recommended workpiece weight kg	1,5	3	1,5	3	1,5	3
Weight kg	0,3	0,3	0,4	0,4	0,4	0,4
Width mm	76	76	76	76	76	76
Height mm	39	39	57	57	57	57
Depth mm	36	36	36	36	36	36
Mx Nm	40	40	40	40	40	40
My Nm	60	60	60	60	60	60
Mz Nm	40	40	40	40	40	40
Fz N	1100	1100	1100	1100	1100	1100
Operating pressure min./max. without GA/GI bar	2-8	2-8	-	-	-	-
Operating pressure min./max. with GA/GI bar	-	-	4-7	4-7	4-7	4-7
Clamping time s	0,03	0,03	0,02	0,02	0,04	0,04
Opening time s	0,03	0,03	0,04	0,04	0,02	0,02
Air consumption per cycle cm ³	10	10	10	10	10	10
Max. allowable length of jaw mm	90	85	85	80	85	80

RPP-64

Max. load on gripper and jaw

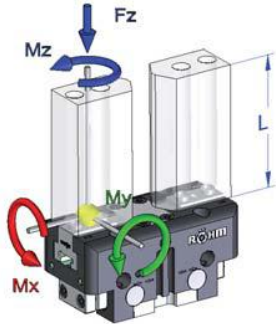

Clamping force diagram exterior gripping

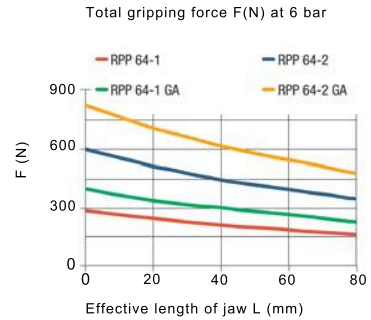

RPP 64-1:22
RPP 64-2:25

RPP 64-1 MAX. 40,5 ; MIN.28,5
RPP 64-2 MAX.34,5 ; MIN.28,5

Tubeless direct connection

T-nut for distance measurement

Sensor holder Ø8 (2x)
C-nut for magnetic sensors

Section A-A

M5 /6 deep for sealing air

Type GA/GI with gripping force safety device

Accessories: Protective cover

Height RPP 64-1/2: 44,5
Height RPP 64-1/2 GA/GI: 62,5

Parallel gripper RPP

RPP-80



APPLICATION

Universal gripping of round and angular workpieces with two parallel gripper fingers for handling with robots or portals.

TYPE

Available from sizes 50 to 380, each in two stroke variants. Optionally with gripping force safety device and/or dirt cover. Fastening of the gripper fingers via centering sleeves (included in the scope of delivery).

CUSTOMER BENEFITS

- ⊕ High gripping force with low dead weight and compact design
- ⊕ High torque support for using long gripper fingers thanks to elongated jaw guide
- ⊕ Maximum flexibility thanks to versatile connection and fastening options
- ⊕ Long service life and high reliability thanks to specially ground base jaws in proven T-slot guide

TECHNICAL FEATURES

- Centrally clamping in compact design made of high-strength, hard-coated aluminum alloy
- All functional parts made of hardened steel for maximum service life
- Wedge hook principle with pneumatic actuation (hydraulic actuation available on request)
- Position monitoring with inductive or magnetic position sensors
- Optionally available with FKM seals for higher temperatures up to 150°C (on request)
- Integrated purge air connection to prevent contamination

C40

RPP-80 - 2-jaw parallel gripper air operated

Item no.	170007	170008 ▲	170009	170010 ▲	170011 ▲	170012 ▲
Design	RPP-80-1	RPP-80-2	RPP-80-1/GA	RPP-80-2/GA	RPP-80-1/GI	RPP-80-2/GA
Gripping force at 6 bar N	470	886	615	1156	657	1236
Stroke per jaw mm	8	4	8	4	8	4
Gripping force maintained N	-	-	160	300	160	300
Recommended workpiece weight kg	2,2	4,3	2,2	4,3	2,2	4,3
Weight kg	0,5	0,5	0,6	0,6	0,6	0,6
Width mm	96	96	96	96	96	96
Height mm	49	49	67	67	67	67
Depth mm	42	42	42	42	42	42
Mx Nm	60	60	60	60	60	60
My Nm	95	95	95	95	95	95
Mz Nm	55	55	55	55	55	55
Fz N	1500	1500	1500	1500	1500	1500
Operating pressure min./max. without GA/GI bar	2-8	2-8	-	-	-	-
Operating pressure min./max. with GA/GI bar	-	-	4-7	4-7	4-7	4-7
Clamping time s	0,04	0,04	0,03	0,03	0,05	0,05
Opening time s	0,04	0,04	0,05	0,05	0,03	0,03
Air consumption per cycle cm ³	21	21	21	21	21	21
Max. allowable length of jaw mm	110	105	105	100	105	100

RPP-80

Max. load on gripper and jaw

Clamping force diagram exterior gripping

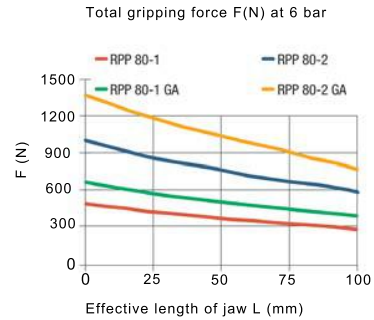
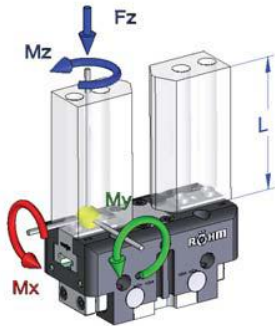

Type GA/GI with gripping force safety device

Accessories: Protective cover

Parallel gripper RPP

RPP-100



APPLICATION

Universal gripping of round and angular workpieces with two parallel gripper fingers for handling with robots or portals.

TYPE

Available from sizes 50 to 380, each in two stroke variants. Optionally with gripping force safety device and/or dirt cover.

Fastening of the gripper fingers via centering sleeves (included in the scope of delivery).

CUSTOMER BENEFITS

- ⊕ High gripping force with low dead weight and compact design
- ⊕ High torque support for using long gripper fingers thanks to elongated jaw guide
- ⊕ Maximum flexibility thanks to versatile connection and fastening options
- ⊕ Long service life and high reliability thanks to specially ground base jaws in proven T-slot guide

TECHNICAL FEATURES

- Centrally clamping in compact design made of high-strength, hard-coated aluminum alloy
- All functional parts made of hardened steel for maximum service life
- Wedge hook principle with pneumatic actuation (hydraulic actuation available on request)
- Position monitoring with inductive or magnetic position sensors
- Optionally available with FKM seals for higher temperatures up to 150°C (on request)
- Integrated purge air connection to prevent contamination

C40

RPP-100 - 2-jaw parallel gripper air operated

Item no.	170013	170014	170015	170016	170018 ▲	170019 ▲
Design	RPP-100-1	RPP-100-2	RPP-100-1/GA	RPP-100-2/GA	RPP-100-1/GI	RPP-100-2/GI
Gripping force at 6 bar N	830	1570	981	1857	1044	1977
Stroke per jaw mm	10	5	10	5	10	5
Gripping force maintained N	-	-	260	500	260	450
Recommended workpiece weight kg	3,5	7	3,5	7	3,5	7
Weight kg	0,8	0,8	1	1	1	1
Width mm	120	120	120	120	120	120
Height mm	55	55	81	81	81	81
Depth mm	50	50	50	50	50	50
Mx Nm	80	80	80	80	80	80
My Nm	115	115	115	115	115	115
Mz Nm	70	70	70	70	70	70
Fz N	2000	2000	2000	2000	2000	2000
Operating pressure min./max. without GA/GI bar	2-8	2-8	-	-	-	-
Operating pressure min./max. with GA/GI bar	-	-	4-7	4-7	4-7	4-7
Clamping time s	0,07	0,07	0,05	0,05	0,09	0,09
Opening time s	0,07	0,07	0,09	0,09	0,05	0,05
Air consumption per cycle cm ³	40	40	40	40	40	40
Max. allowable length of jaw mm	145	135	135	125	135	125

RPP-100

Max. load on gripper and jaw

Clamping force diagram exterior gripping

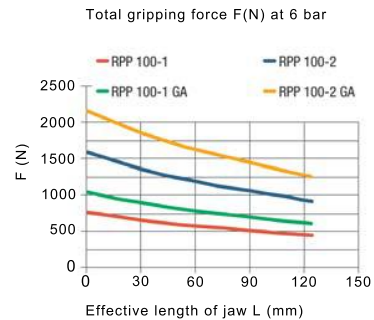
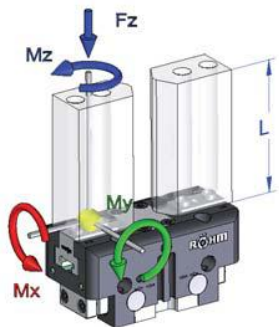

RPP 100-1: 33
RPP 100-2: 38

RPP 100-1 MAX. 67; MIN. 47
RPP 100-2 MAX. 57; MIN. 47

Tubeless direct connection

G1/8" (2x) air connection

Sleeve Ø10 for gripper connection

Section A-A

Type GA/GI with gripping force safety device

Accessories: Protective cover

Height RPP 100-1/2: 61.5
Height RPP 100-1/2 GA/GI: 87.5

RPP 100-1 MAX. 67; MIN. 47
RPP 100-2 MAX. 57; MIN. 47

Parallel gripper RPP

RPP-125



APPLICATION

Universal gripping of round and angular workpieces with two parallel gripper fingers for handling with robots or portals.

TYPE

Available from sizes 50 to 380, each in two stroke variants. Optionally with gripping force safety device and/or dirt cover.

Fastening of the gripper fingers via centering sleeves (included in the scope of delivery).

CUSTOMER BENEFITS

- ⊕ High gripping force with low dead weight and compact design
- ⊕ High torque support for using long gripper fingers thanks to elongated jaw guide
- ⊕ Maximum flexibility thanks to versatile connection and fastening options
- ⊕ Long service life and high reliability thanks to specially ground base jaws in proven T-slot guide

TECHNICAL FEATURES

- Centrally clamping in compact design made of high-strength, hard-coated aluminum alloy
- All functional parts made of hardened steel for maximum service life
- Wedge hook principle with pneumatic actuation (hydraulic actuation available on request)
- Position monitoring with inductive or magnetic position sensors
- Optionally available with FKM seals for higher temperatures up to 150°C (on request)
- Integrated purge air connection to prevent contamination

C40

RPP-125 - 2-jaw parallel gripper air operated

Item no.	170020	170021	170022	170023	170025	170026
Design	RPP-125-1	RPP-125-2	RPP-125-1/GA	RPP-125-2/GA	RPP-125-1/GI	RPP-125-2/GI
Gripping force at 6 bar N	1243	2500	1568	3162	1625	3277
Stroke per jaw mm	13	6	13	6	13	6
Gripping force maintained N	-	-	350	750	350	750
Recommended workpiece weight kg	6,2	12,5	6,2	12,5	6,2	12,5
Weight kg	1,5	1,5	1,9	1,9	1,9	1,9
Width mm	151	151	151	151	151	151
Height mm	63	63	93	93	93	93
Depth mm	60	60	60	60	60	60
Mx Nm	120	120	120	120	120	120
My Nm	145	145	145	145	145	145
Mz Nm	100	100	100	100	100	100
Fz N	2800	2800	2800	2800	2800	2800
Operating pressure min./max. without GA/GI bar	2-8	2-8	-	-	-	-
Operating pressure min./max. with GA/GI bar	-	-	4-7	4-7	4-7	4-7
Clamping time s	0,1	0,1	0,08	0,08	0,12	0,12
Opening time s	0,1	0,1	0,12	0,12	0,08	0,08
Air consumption per cycle cm ³	80	80	80	80	80	80
Max. allowable length of jaw mm	180	170	170	160	170	160

RPP-125

Max. load on gripper and jaw

Clamping force diagram exterior gripping

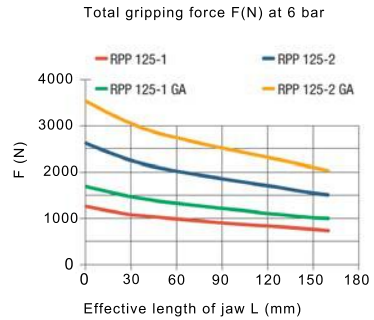
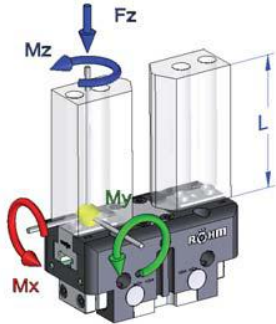

RPP 125-1: 39
RPP 125-2: 46

RPP 125-1 MAX. 87; MIN. 61
RPP 125-2 MAX. 73; MIN. 61

Tubeless direct connection

Adapter Gripper

Ø7 Ø4 M5 1.1 O-ring Ø4x1,5

Sensor holder Ø8 (2x)
C-nut for magnetic sensors

G1/8" / 8 deep (2x) air connection
M5 / 6 deep for sealing air
M6 (4x) Ø10 h6 (4x)

Sleeve Ø12 for gripper connection

Ø12 h6 (2x) M6 (4x) M8 (4x) 3 20 23 Ø9 Ø14 (2x) Ø6.8 Ø11 (4x) 28

M5 / 6 deep (2x) air connection
M5/6 deep for sealing air

Type GA/GI with gripping force safety device

Accessories: Protective cover

MAX. 192

RPP 125-1 MAX. 87; MIN. 61
RPP 125-2 MAX. 73; MIN. 61

166

Height RPP 125-1/2: 69,5
Height RPP 125-1/2 GA/GI: 99,5

4 3.5

RPP-160



APPLICATION

Universal gripping of round and angular workpieces with two parallel gripper fingers for handling with robots or portals.

TYPE

Available from sizes 50 to 380, each in two stroke variants. Optionally with gripping force safety device and/or dirt cover. Fastening of the gripper fingers via centering sleeves (included in the scope of delivery).

CUSTOMER BENEFITS

- ⊕ High gripping force with low dead weight and compact design
- ⊕ High torque support for using long gripper fingers thanks to elongated jaw guide
- ⊕ Maximum flexibility thanks to versatile connection and fastening options
- ⊕ Long service life and high reliability thanks to specially ground base jaws in proven T-slot guide

TECHNICAL FEATURES

- Centrally clamping in compact design made of high-strength, hard-coated aluminum alloy
- All functional parts made of hardened steel for maximum service life
- Wedge hook principle with pneumatic actuation (hydraulic actuation available on request)
- Position monitoring with inductive or magnetic position sensors
- Optionally available with FKM seals for higher temperatures up to 150°C (on request)
- Integrated purge air connection to prevent contamination

C40

RPP-160 - 2-jaw parallel gripper air operated

Item no.	170029	170030	170031	170032	170033	170034
Design	RPP-160-1	RPP-160-2	RPP-160-1/GA	RPP-160-2/GA	RPP-160-1/GI	RPP-160-2/GI
Gripping force at 6 bar N	2000	3775	2555	4805	2664	5010
Stroke per jaw mm	16	8	16	8	16	8
Gripping force maintained N	-	-	550	1100	550	1100
Recommended workpiece weight kg	9	17	9	17	9	17
Weight kg	2,8	2,8	3,6	3,6	3,6	3,6
Width mm	192	192	192	192	192	192
Height mm	77	77	117	117	117	117
Depth mm	72	72	72	72	72	72
Mx Nm	170	170	170	170	170	170
My Nm	180	180	180	180	180	180
Mz Nm	130	130	130	130	130	130
Fz N	4300	4300	4300	4300	4300	4300
Operating pressure min./max. without GA/GI bar	2-8	2-8	-	-	-	-
Operating pressure min./max. with GA/GI bar	-	-	4-7	4-7	4-7	4-7
Clamping time s	0,15	0,15	0,25	0,25	0,12	0,12
Opening time s	0,15	0,15	0,25	0,25	0,12	0,12
Air consumption per cycle cm ³	160	160	160	160	160	160
Max. allowable length of jaw mm	220	210	210	200	210	200

RPP-160

Max. load on gripper and jaw

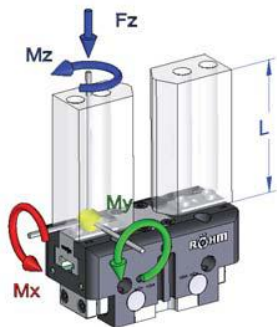

Clamping force diagram exterior gripping

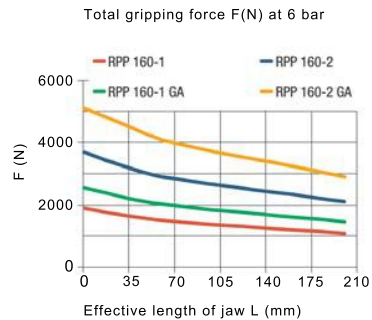

Type GA/GI with gripping force safety device

Accessories: Protective cover

Parallel gripper RPP

RPP-200



APPLICATION

Universal gripping of round and angular workpieces with two parallel gripper fingers for handling with robots or portals.

TYPE

Available from sizes 50 to 380, each in two stroke variants. Optionally with gripping force safety device and/or dirt cover. Fastening of the gripper fingers via centering sleeves (included in the scope of delivery).

CUSTOMER BENEFITS

- ⊕ High gripping force with low dead weight and compact design
- ⊕ High torque support for using long gripper fingers thanks to elongated jaw guide
- ⊕ Maximum flexibility thanks to versatile connection and fastening options
- ⊕ Long service life and high reliability thanks to specially ground base jaws in proven T-slot guide

TECHNICAL FEATURES

- Centrally clamping in compact design made of high-strength, hard-coated aluminum alloy
- All functional parts made of hardened steel for maximum service life
- Wedge hook principle with pneumatic actuation (hydraulic actuation available on request)
- Position monitoring with inductive or magnetic position sensors
- Optionally available with FKM seals for higher temperatures up to 150°C (on request)
- Integrated purge air connection to prevent contamination

C40
RPP-200 - 2-jaw parallel gripper air operated

Item no.	170035	170036	170037	170038	170039 ▲	170040 ▲
Design	RPP-200-1	RPP-200-2	RPP-200-1/GA	RPP-200-2/GA	RPP-200-1/GI	RPP-200-2/GI
Gripping force at 6 bar N	3080	5240	3940	6700	4090	6950
Stroke per jaw mm	25	14	25	14	25	14
Gripping force maintained N	-	-	900	1500	900	1500
Recommended workpiece weight kg	14	24	14	24	14	24
Weight kg	5,5	5,5	7,5	7,5	7,5	7,5
Width mm	234	234	234	234	234	234
Height mm	91	91	141	141	141	141
Depth mm	100	100	100	100	100	100
Mx Nm	180	180	180	180	180	180
My Nm	200	200	200	200	200	200
Mz Nm	140	140	140	140	140	140
Fz N	5000	5000	5000	5000	5000	5000
Operating pressure min./max. without GA/GI bar	2-8	2-8	-	-	-	-
Operating pressure min./max. with GA/GI bar	-	-	4-7	4-7	4-7	4-7
Clamping time s	0,35	0,35	0,3	0,3	0,6	0,6
Opening time s	0,35	0,35	0,6	0,6	0,3	0,3
Air consumption per cycle cm ³	390	390	390	390	390	390
Max. allowable length of jaw mm	280	240	240	200	240	200

RPP-200

Max. load on gripper and jaw

Clamping force diagram exterior gripping

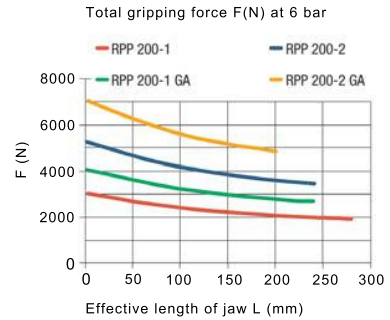
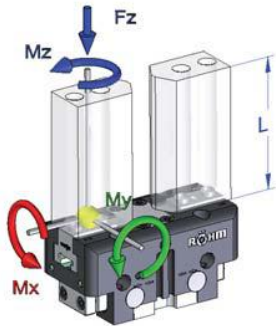

RPP 200-1: 63
RPP 200-2: 74

RPP 200-1 MAX. 126; MIN. 76
RPP 200-2 MAX. 104; MIN. 76

Tubeless direct connection

Adapter Gripper

82±0.2

M5/6 deep (2x) direct connection

Sensor holder Ø8 (2x)

C-nut for magnetic sensors

Sleeve Ø14 for gripper connection

Ø14 h6 (2x)

M8 (4x)

M10 (4x)

4

15

20

70

Ø10.2

Ø17 (2x)

23

Ø8.4

Ø14 (4x)

82±0.2

22±0.2

38

91

17

4

M12 (4x)

Ø16 h6 (4x)

Profondeur G1/8"/8 (2x) air connection

M5 /6 deep for sealing air

190

154

82±0.2

34±0.02

90

130±0.02

22±0.2

M5 /6 deep for air connection

M5 /6 deep for sealing air

Type GA/GI with gripping force safety device

Accessories: Protective cover

MAX. 298

71

45

32

140

141

248

5.5

4

RPP 200-1 MAX. 126; MIN. 76
RPP 200-2 MAX. 104; MIN. 76

Height RPP 200-1/2: 99.5
Height RPP 200-1/2 GA/GI: 149.5

Parallel gripper RPP

RPP-240



APPLICATION

Universal gripping of round and angular workpieces with two parallel gripper fingers for handling with robots or portals.

TYPE

Available from sizes 50 to 380, each in two stroke variants. Optionally with gripping force safety device and/or dirt cover. Fastening of the gripper fingers via centering sleeves (included in the scope of delivery).

CUSTOMER BENEFITS

- ⊕ High gripping force with low dead weight and compact design
- ⊕ High torque support for using long gripper fingers thanks to elongated jaw guide
- ⊕ Maximum flexibility thanks to versatile connection and fastening options
- ⊕ Long service life and high reliability thanks to specially ground base jaws in proven T-slot guide

TECHNICAL FEATURES

- Centrally clamping in compact design made of high-strength, hard-coated aluminum alloy
- All functional parts made of hardened steel for maximum service life
- Wedge hook principle with pneumatic actuation (hydraulic actuation available on request)
- Position monitoring with inductive or magnetic position sensors
- Optionally available with FKM seals for higher temperatures up to 150°C (on request)
- Integrated purge air connection to prevent contamination

C40
RPP-240 - 2-jaw parallel gripper air operated

Item no.	170100	170101	170102	170103	170104	170105
Design	RPP-240-1	RPP-240-2	RPP-240-1/GA	RPP-240-2/GA	RPP-240-1/GI	RPP-240-2/GA
Gripping force at 6 bar N	4309	7324	5256	8934	5526	9392
Stroke per jaw mm	30	17	30	17	30	17
Gripping force maintained N	-	-	1000	1600	1000	1600
Recommended workpiece weight kg	21	35	21	35	21	35
Weight kg	8,8	9,2	12	12	12	12
Width mm	270	270	270	270	270	270
Height mm	107	107	163,5	163,5	163,5	163,5
Depth mm	115	115	115	115	115	115
Mx Nm	260	260	260	260	260	260
My Nm	250	250	250	250	250	250
Mz Nm	160	160	160	160	160	160
Fz N	6200	6200	6200	6200	6200	6200
Operating pressure min./max. without GA/GI bar	2-8	2-8	-	-	-	-
Operating pressure min./max. with GA/GI bar	-	-	4-7	4-7	4-7	4-7
Clamping time s	0,45	0,45	0,35	0,35	0,65	0,65
Opening time s	0,45	0,45	0,65	0,65	0,35	0,35
Air consumption per cycle cm ³	650	650	650	650	650	650
Max. allowable length of jaw mm	320	280	280	240	280	240

RPP-240

Max. load on gripper and jaw

Clamping force diagram exterior gripping

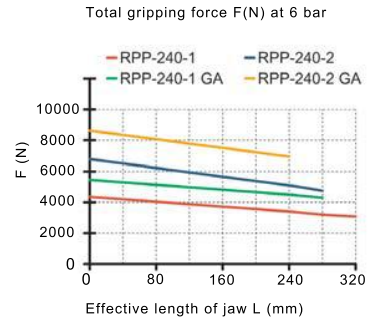
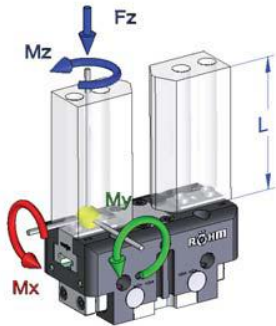

RPP 240-1: 69
RPP 240-2: 82

Tubeless direct connection
Adapter
Gripper
Ø7
Ø4
M5
1,1
O-ring Ø4x1,5

RPP 240-1 MAX. 153,5; MIN. 93,5
RPP 240-2 MAX. 127,5; MIN. 93,5

Sensor holder Ø8 (2x)
C-nut for magnetic sensors

M5/6 deep (2x) direct connection

115^{+0,2}
80^{+0,02}
96^{±0,2}
160^{±0,02}
204

G1/8" / 8 deep (2x) air connection
M5 / 6 deep for sealing air

Sleeve Ø16 for gripper connection

Ø16 h6 (2x)
M10 (4x)
M12 (4x)
14,5
4
25,5
80,5
Ø12,5
Ø19 (2x)
30
Ø10,1
Ø18 (4x)

M5 / 6 deep for air connection
M5 / 6 deep for sealing air

218
186
96^{±0,2}
39^{±0,02}
106
160^{±0,02}
25,3^{±0,2}

Type GA/GI with gripping force safety device

186
105,5
56,5
162,5
163,5
270

Accessories: Protective cover

MAX. 348
86
51
38
RPP 240-1 MAX. 153,5; MIN. 93,5
RPP 240-2 MAX. 127,5; MIN. 93,5
288
5,5
4
Height RPP 240-1/2: 115,5
Height RPP 240-1/2 GA/GI: 172

Parallel gripper RPP

RPP-300



APPLICATION

Universal gripping of round and angular workpieces with two parallel gripper fingers for handling with robots or portals.

TYPE

Available from sizes 50 to 380, each in two stroke variants. Optionally with gripping force safety device and/or dirt cover. Fastening of the gripper fingers via centering sleeves (included in the scope of delivery).

CUSTOMER BENEFITS

- ⊕ High gripping force with low dead weight and compact design
- ⊕ High torque support for using long gripper fingers thanks to elongated jaw guide
- ⊕ Maximum flexibility thanks to versatile connection and fastening options
- ⊕ Long service life and high reliability thanks to specially ground base jaws in proven T-slot guide

TECHNICAL FEATURES

- Centrally clamping in compact design made of high-strength, hard-coated aluminum alloy
- All functional parts made of hardened steel for maximum service life
- Wedge hook principle with pneumatic actuation (hydraulic actuation available on request)
- Position monitoring with inductive or magnetic position sensors
- Optionally available with FKM seals for higher temperatures up to 150°C (on request)
- Integrated purge air connection to prevent contamination

C40
RPP-300 - 2-jaw parallel gripper air operated

Item no.	170041	170042	170043	170044	170045 ▲	170046 ▲
Design	RPP-300-1	RPP-300-2	RPP-300-1/GA	RPP-300-2/GA	RPP-300-1/GI	RPP-300-2/GI
Gripping force at 6 bar N	6400	11000	7590	12910	7860	13360
Stroke per jaw mm	35	20	35	20	35	20
Gripping force maintained N	-	-	1300	2200	1300	2200
Recommended workpiece weight kg	31	52	31	52	31	52
Weight kg	14	14	17	17	17	17
Width mm	320	320	320	320	320	320
Height mm	122	122	172	172	172	172
Depth mm	140	140	140	140	140	140
Mx Nm	400	400	400	400	400	400
My Nm	400	400	400	400	400	400
Mz Nm	250	250	250	250	250	250
Fz N	8000	8000	8000	8000	8000	8000
Operating pressure min./max. without GA/GI bar	2-8	2-8	-	-	-	-
Operating pressure min./max. with GA/GI bar	-	-	4-7	4-7	4-7	4-7
Clamping time s	0,5	0,5	0,4	0,4	0,7	0,7
Opening time s	0,5	0,5	0,7	0,7	0,4	0,4
Air consumption per cycle cm ³	1040	1040	1040	1040	1040	1040
Max. allowable length of jaw mm	350	300	300	250	300	250

RPP-300

Max. load on gripper and jaw

Clamping force diagram exterior gripping

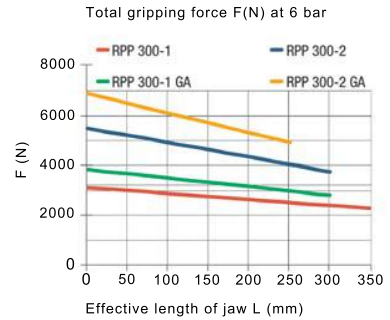
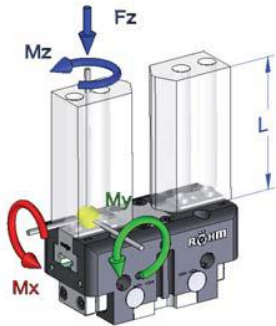

Type GA/GI with gripping force safety device

Accessories: Protective cover

Parallel gripper RPP

RPP-380



APPLICATION

Universal gripping of round and angular workpieces with two parallel gripper fingers for handling with robots or portals.

TYPE

Available from sizes 50 to 380, each in two stroke variants. Optionally with gripping force safety device and/or dirt cover. Fastening of the gripper fingers via centering sleeves (included in the scope of delivery).

CUSTOMER BENEFITS

- ⊕ High gripping force with low dead weight and compact design
- ⊕ High torque support for using long gripper fingers thanks to elongated jaw guide
- ⊕ Maximum flexibility thanks to versatile connection and fastening options
- ⊕ Long service life and high reliability thanks to specially ground base jaws in proven T-slot guide

TECHNICAL FEATURES

- Centrally clamping in compact design made of high-strength, hard-coated aluminum alloy
- All functional parts made of hardened steel for maximum service life
- Wedge hook principle with pneumatic actuation (hydraulic actuation available on request)
- Position monitoring with inductive or magnetic position sensors
- Optionally available with FKM seals for higher temperatures up to 150°C (on request)
- Integrated purge air connection to prevent contamination

C40

RPP-380 - 2-jaw parallel gripper air operated

Item no.	172113	172114	172115	172116	172117 ▲	172118 ▲
Design	RPP-380-1	RPP-380-2	RPP-380-1/GA	RPP-380-2/GA	RPP-380-1/GI	RPP-380-2/GI
Gripping force at 6 bar N	9620	16350	12470	21200	12900	21900
Stroke per jaw mm	45	26	45	26	45	26
Gripping force maintained N	-	-	2850	4850	2850	4850
Recommended workpiece weight kg	48	82	35,5	82	48	82
Weight kg	28	28	35,5	35,5	35,5	35,5
Width mm	310	410	410	410	410	410
Height mm	226,5	155	226,5	226,5	226,5	226,5
Depth mm	170	170	170	170	170	170
Mx Nm	560	560	560	560	560	560
My Nm	560	560	560	560	560	560
Mz Nm	370	370	370	370	370	370
Fz N	10000	10000	10000	10000	10000	10000
Operating pressure min./max. without GA/GI bar	2,5-8	2,5-8				
Operating pressure min./max. with GA/GI bar			4-6,5	4-6,5	4-6,5	4-6,5
Clamping time s	0,6	0,6	0,45	0,45	0,8	0,8
Opening time s	0,6	0,6	0,8	0,8	0,5	0,5
Max. allowable length of jaw mm	400	350	350	300	350	300

RPP-380

Max. load on gripper and jaw

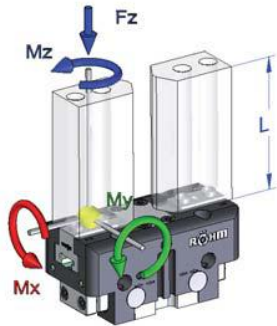

Clamping force diagram exterior gripping

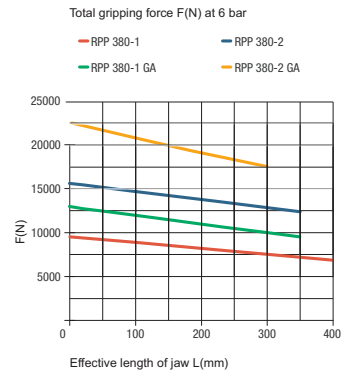

Type GA/GI with gripping force safety device

Accessories: Protective cover

Accessories RPP

Jaw blank - steel (including fixing screws) 2-jaw set



Item no.	Number of jaws	Design	For
170574 ▲	2	steel	RPP-50
170575 ▲	2	steel	RPP-64
170576 ▲	2	steel	RPP-80
170577 ▲	2	steel	RPP-100
170578 ▲	2	steel	RPP-125
170579 ▲	2	steel	RPP-160
170580 ▲	2	steel	RPP-200
170581 ▲	2	steel	RPP-240
170582 ▲	2	steel	RPP-300
170583 ▲	2	steel	RPP-380

Jaw blank - aluminium (including fixing screws) 2-jaw set



Item no.	Number of jaws	Design	For
170584 ▲	2	aluminium	RPP-50
170585 ▲	2	aluminium	RPP-64
170586 ▲	2	aluminium	RPP-80
170587 ▲	2	aluminium	RPP-100
170588 ▲	2	aluminium	RPP-125
170589 ▲	2	aluminium	RPP-160
170590 ▲	2	aluminium	RPP-200
170591 ▲	2	aluminium	RPP-240
170592 ▲	2	aluminium	RPP-300
170593 ▲	2	aluminium	RPP-380

Protective cover



Item no.	For
170594	RPP-50
170540	RPP-64
170541	RPP-80
170542	RPP-100
170543	RPP-125
170544	RPP-160
170545	RPP-200
170546	RPP-240
170547	RPP-300
170548	RPP-380

Compressed air connection



Item no.	Design	For
802539	L-Plug connector M5 - 6 mm	RPP-50 / RPP-64 / RPP-80
477025	L-Plug connector 1/8 - 6 mm	RPP-100 - RPP-240
477024	L-Plug connector 1/4 - 6 mm	RPP-300 / RPP-380

Pressure maintenance for double acting gripper (G1/8)



Item no.
1078823

Proximity switch



Item no.	Size (diameter/ length)	Design	For
1149503	3x27	30 cm cable, plug M8x1-S49	RPP-50
229114	M8x1x30,5	5 m cable, open leads	RPP-64 / RPP- 80 / RPP-100
389661	M8x1x46,5	3 m cable, open leads	RPP-125 - RPP-380

Magnetic field sensors



Item no.	Size (diameter/length)	Design	For
1306268	C-Nut	2 m cable, open leads	RPP-50
1276722	C-Nut	3 m cable, 3 open leads	all sizes, all types

Accessories RPP

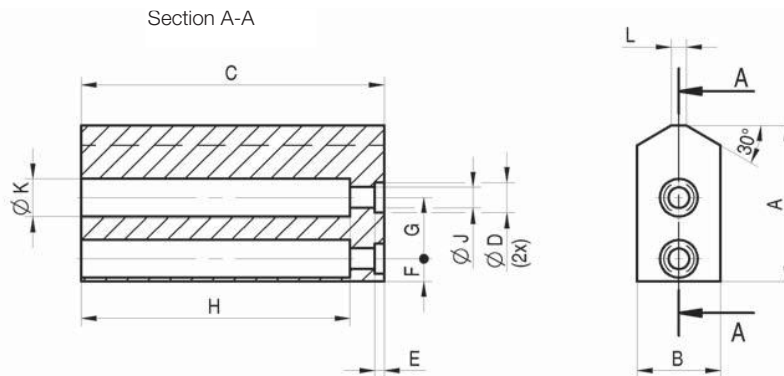
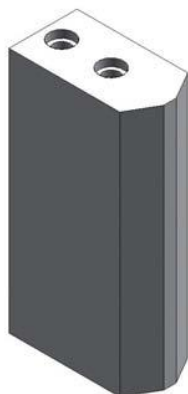

Jaw blank - steel (including fixing screws), 2-jaw set

RPP / RZP	50	64	80	100	125	160	200	240	300
RPP - 2-jaw set	170574	170575	170576	170577	170578	170579	170580	170581	170582
RZP - 3-jaw set	170596	170500	170502	170504	170506	170508	170510	170512	170514
A	30	32	41	51	60	80	96	109	130
B	15	20	22	30	35	40	40	50	60
C	50	64	80	100	125	160	200	220	200
D +0,04/+0,02	5	6	8	10	10	14	16	16	22
E+0,2	2	2,5	2,5	3	3	4	4	4	6
F±0,1	5	5	6	7	9,5	10	15	15,5	20
G±0,1	12	13	16	20	24	32	40	44	46
H	45	57	71	91	115	146	181	204	177
J	3,4	4,5	5,5	6,6	6,6	11	13,5	13,5	17,5
K	6	8	10	11	11	18	20	20	26
L	2	3	4	5	6	8	13	10	16
Weight per jaw Kg	0,15	0,25	0,45	1,0	1,75	3,2	5,0	8,0	10,2

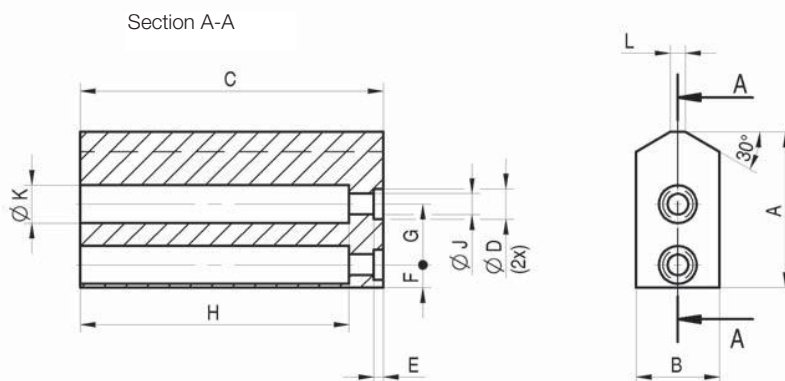
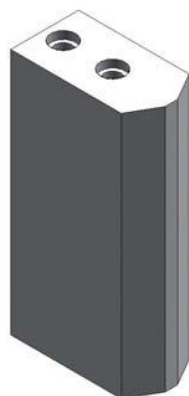

Jaw blank - aluminium (including fixing screws), 2-jaw set

RPP / RZP	50	64	80	100	125	160	200	240	300
RPP - 2-jaw set	170584	170585	170586	170587	170588	170589	170590	170591	170592
RZP - 3-jaw set	170597	170550	170552	170554	170556	170558	170560	170562	170564
A	30	32	41	51	60	80	96	109	130
B	15	20	25	30	35	40	45	50	60
C	50	64	80	100	125	160	200	220	200
D +0,04/+0,02	5	6	8	10	10	14	16	16	22
E+0,2	2	2,5	2,5	3	3	4	4	4	6
F±0,1	5	5	6	7	9,5	10	15	15,5	20
G±0,1	12	13	16	20	24	32	40	44	46
H	43	55	69	88	112	141	176	200	170
J	3,4	4,5	5,5	6,6	6,6	11	13,5	13,5	17,5
K	6	8	10	11	11	18	20	20	26
L	2	3	4	5	6	8	9	10	16
Weight per jaw Kg	0,05	0,1	0,18	0,35	0,6	1,2	2,0	2,8	3,4