



**APPLICATION**

For conventional machine tools.

**TYPE**

Clamping system mechanical without power transmitter, manually operated.

**CUSTOMER BENEFITS**

- ⊕ Optimal price/performance ratio
- ⊕ Entire clamping range can be bridged over by turning the handcrank
- ⊕ Spindle is protected from dirt and chips
- ⊕ Extensive assortment of jaws

**TECHNICAL FEATURES**

- Made of special cast iron for versatile use
- Long guidance of moving jaw
- Force transfer by means of threaded spindle
- With normal jaws SGN and handcrank
- Use on rotary plate with graduation

A11  
RS, with SGN normal jaws and hand crank

RS machine vice

Item no.	128031	128032	128033	128034	111648
Size	1	2	3	4	5
Jaw width A mm	92	113	135	160	200
B mm	85	105	125	145	185
C mm	31,6	31,6	39,6	49,6	62,6
D mm	362	423	510	575	675
F mm	260	300	365	410	460
G mm	48	58	64	70	82
H mm	50	55	70	80	90
J mm	174	200	242	273	322
K mm	160	160	200	240	280
O mm	115	125	155	175	200
P mm	60	60	70	80	118
Q mm	13	13	13	17	21
R mm	14	14	14	18	22
S mm	120	120	146	184,5	210
Y mm	12	12	16	16	20
a mm	63	63	80	100	125
b mm	13,6	13,6	15,6	19,6	24,6
c	M6	M6	M8	M8	M10
Clamping force kN	18	25	35	45	55
Weight kg	12	13,5	25	40	65



RS machine vice

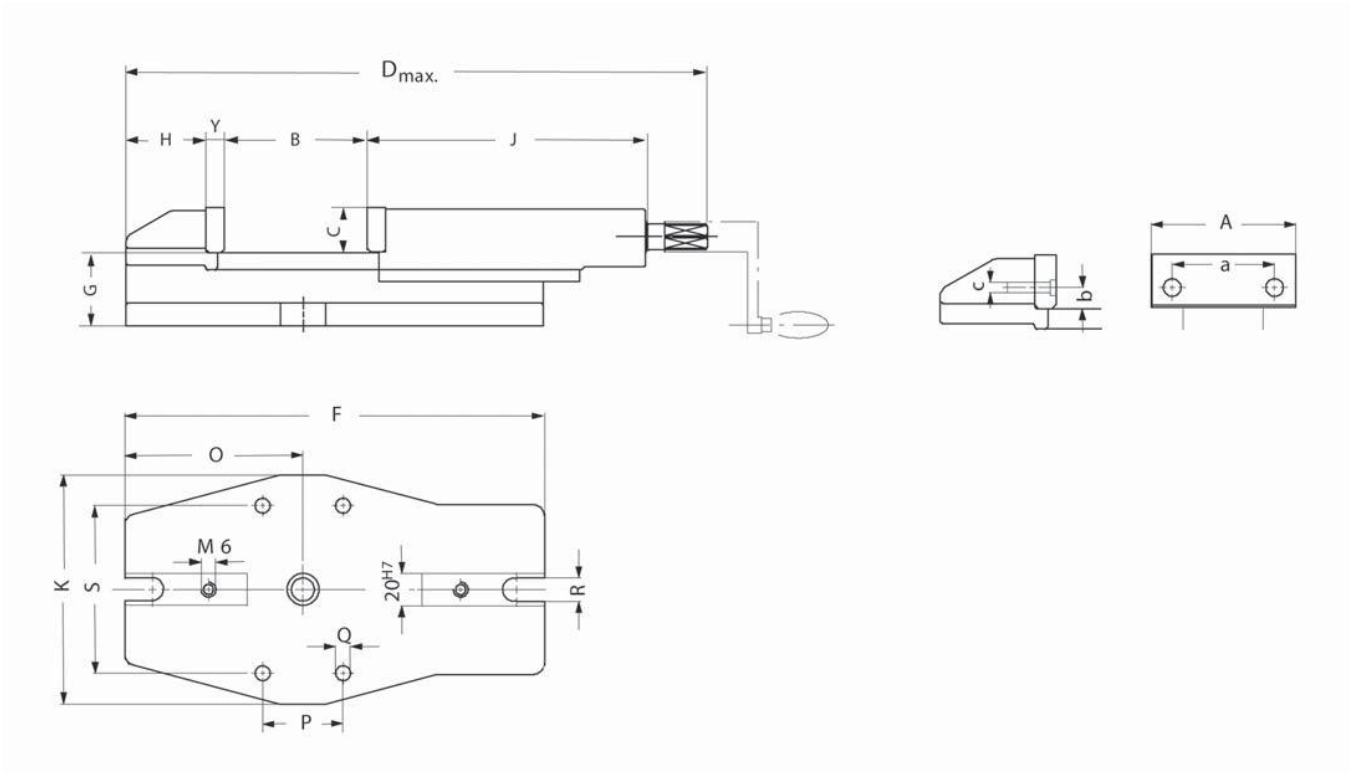

# Accessories RS

A37  
**Draw-down jaws SNF**, with spring plate, hardened and ground



Item no.	Contents of delivery	Size	Width mm	Height mm
077104	set	2a	113	31,6
077105	set	125	135	39,6
077106	set	160	160	49,6
077107	set	200	200	62,6

A37  
**Standard jaws SGN**, one side smooth, one side grooved, hardened and ground



Item no.	Contents of delivery	Size	Width mm	Height mm
152752	piece	1	92	31,6
152753	piece	2	113	31,6
152754	piece	3	135	39,6
152755	piece	4	160	49,6
152759	piece	5	200	62,6

<sup>1)</sup> both sides ground

Accessories machine  
vices RS

A37  
**Normal jaw finely checkered SGNf**, reversible, to increase the specific contact pressure (higher holding forces), one side finely checkered, one side longitudinally grooved



Item no.	Contents of delivery	Size	Width mm	Height mm
163218	piece	92	92	31,6
156195	piece	2a	113	31,6
156196	piece	3	135	39,6
156197	piece	160	160	49,6
156198	piece	200	200	62,6

A37  
**V-jaw SPR**, with vertically and horizontally ground-in prisms, hardened, for combination with SGN, only suitable for double clamping



Item no.	Contents of delivery	Size	Width mm	Height mm	Chuck capacity mm	
					Horizontal	Vertical
128770	piece	92	92	31,6	3-13	5-32
082362	piece	2a	113	31,6	3-13	5-32
082363	piece	125	135	39,6	4-20	6-40
082364	piece	160	160	49,6	5-29	7-48
082365	piece	200	200	62,6	6-37	8-56

A37  
**Normal jaw SGNA**, with movable workpiece stop, hardened and ground, only suitable for double clamping



Item no.	Contents of delivery	Size	Width mm	Height mm
150739	piece	2a	113	31,6
150740	piece	125	135	39,6
150741	piece	4	160	49,6

# Accessories RS

C15  
Hand crank HKU, with octagon socket



Item no.	Contents of delivery	Size	Octagon	L mm
009150	piece	50	12	80
009152	piece	70	14	125
009153	piece	92	17	160
009154	piece	125	19	200

A37  
Standard rotation plate DP, with fixing screws and T-slot nuts, ground contact edge, graduation



Item no.	Size	External Ø mm	Height mm	Center Ø mm	Weight
129814	1/2	242	30	28	7,5
082442	3	280	30	28	11
082443	4	340	34	28	18

A37  
Universal rotation plate DP, with fixing screws and T-slot nuts, ground contact edge, graduation



Item no.	Size	External Ø mm	Height mm	Center Ø mm	Weight
090854	5	420	40	28	23

Accessories machine  
vices RS