



### APPLICATION

For universal use on milling machines and machining centers.

### TYPE

Clamping system mechanical-hydraulic with power transmitter, manually operated.

### CUSTOMER BENEFITS

- ⊕ Horizontal, vertical and laterally clampable with height adjustment  $\pm 0.02$
- ⊕ Sturdy, maintenance-free spindle
- ⊕ Additional stepped jaws or special form jaws can be fastened to the surface of the stationary and moving jaw
- ⊕ Drive spindle is protected against dirt and chips
- ⊕ Large clamping range
- ⊕ Short version of moving jaw (made of steel) results in short design length, even for max. clamping width
- ⊕ With angle drive

### TECHNICAL FEATURES

- Steel body with stationary clamping jaw, uniformly forged into the die
- Automatic reclamping in the hydraulic unit by means of built-in disc springs
- All wear parts, especially the jaw guides, are hardened and ground
- Robust flat-trajectory guide of moving jaw
- With normal jaws and hand crank

A27  
RBAW, with SGN normal jaws, hand crank and angle drive

Item no.	154763	154764	154765
Size	2	3	4
Jaw width A mm	113	135	160
B1 mm	0-175	0-225	0-310
B2 mm	125-300	138-363	146-454
B3 mm	199-374	220-445	248-556
C mm	31,6	39,6	49,6
Dmax mm	500	578	702
E $\pm 0,02$ mm	97,7	112,7	133,7
F mm	390	468	574
G $\pm 0,02$ mm	65,5	72,5	83,5
H $\pm 0,02$ mm	55	70	80
J mm	211	213	240
K $\pm 0,02$ mm	115	137	162
L $\pm 0,02$ mm	190	190	240
M mm	73,5	80,5	96
T $\pm 0,02$ mm	17,5	17,5	22,5
Y-0,01 mm	11,6	15,6	15,6
a mm	63	80	100
b mm	13,6	15,6	19,6
c mm	M6	M8	M8
d mm	12	13	13
e $\pm 0,02$ mm	96	111	132
f mm	82	80	100
g mm	16	30	30
h mm	M 8 x 14	M10x16	M12x20
i mm	63	80	100
k mm	30	30	30
l mm	85	105	120
m mm	30	35	35
n mm	52	70	96
o mm	135	135	142
pH7 mm	12	14	14
q mm	5	5	5
Clamping force kN	30	40	50
Weight kg	22	36	62

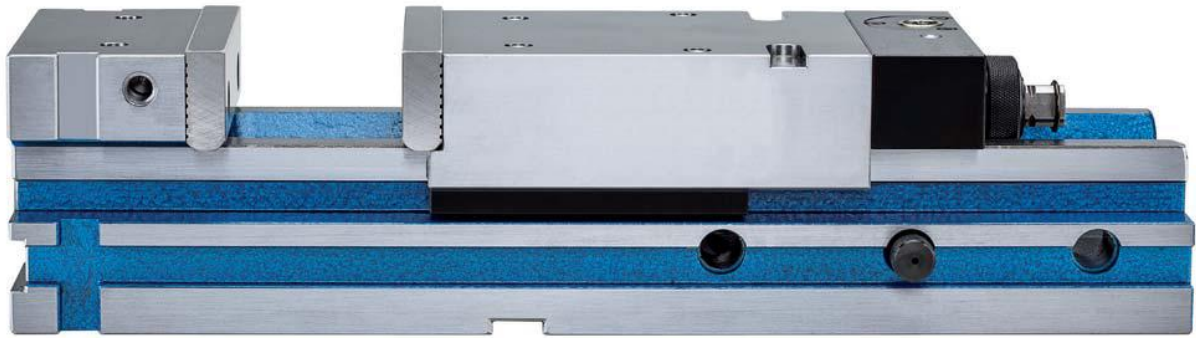

NC power vices RBAW

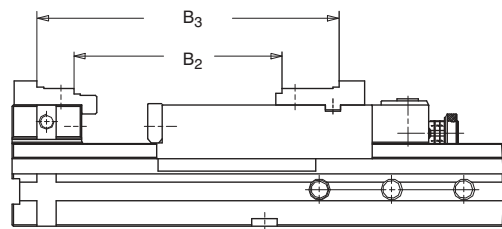
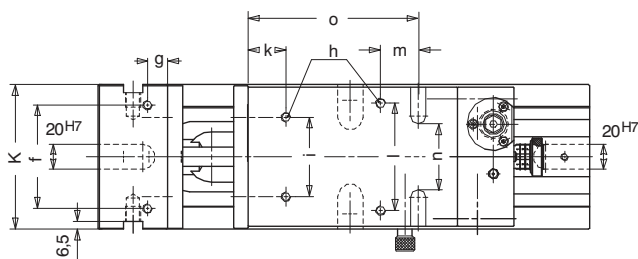
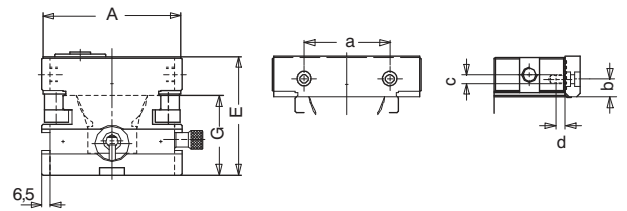
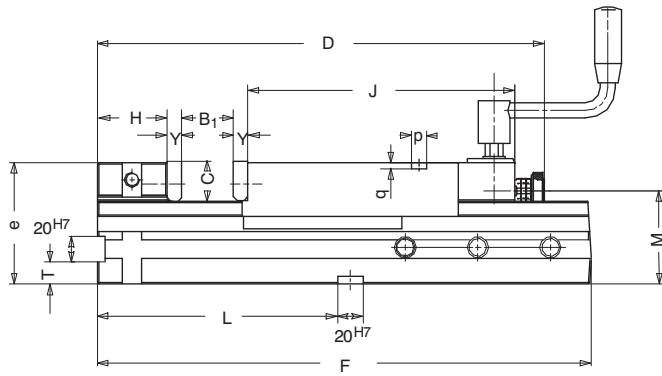

# Accessories RBAW

A37  
**Draw-down jaws SNF**, with spring plate, hardened and ground



Item no.	Contents of delivery	Size	Width mm	Height mm
077104	set	2a	113	31,6
077105	set	125	135	39,6
077106	set	160	160	49,6

A37  
**Normal jaw SGN**, one side smooth, one side grooved, both sides ground



Item no.	Contents of delivery	Size	Width mm	Height mm
152753	piece	2a	113	31,6
152754	piece	3	135	39,6
152755	piece	160	160	49,6

A37  
**Normal jaw finely checkered SGNf**, reversible, to increase the specific contact pressure (higher holding forces), one side finely checkered, one side longitudinally grooved



Item no.	Contents of delivery	Size	Width mm	Height mm
156195	piece	2a	113	31,6
156196	piece	3	135	39,6
156197	piece	160	160	49,6

A37  
**V-jaw SPR**, with vertically and horizontally ground-in prisms, hardened, for combination with SGN, only suitable for double clamping



Item no.	Contents of delivery	Size	Width mm	Height mm	Chuck capacity mm	
					Horizontal	Vertical
082362	piece	2a	113	31,6	3-13	5-32
082363	piece	125	135	39,6	4-20	6-40
082364	piece	160	160	49,6	5-29	7-48

A37  
**V-jaw and standard jaw SBO**, unhardened and burnished, with workpiece support



Item no.	Contents of delivery	Size	Width mm	Height mm	Chuck capacity mm	
					Horizontal	Vertical
317259	set	2a	110	31,8	3-12	5-32
317260	set	125	135	39,8	3-13	6-40
317261	set	4	160	49,8	5-22	7-48

# Accessories RBAW

A37

**Normal jaw SGNA**, with movable workpiece stop, hardened and ground, only suitable for double clamping



Item no.	Contents of delivery	Size	Width mm	Height mm
150739	piece	2a	113	31,6
150740	piece	125	135	39,6
150741	piece	4	160	49,6

A37

**Draw-down jaws STB**, for parallel, angular or flat workpieces, hardened and ground



Item no.	Contents of delivery	Size	Width mm	Height mm
134826	set	2	110	32
134830	set	3	135	40
134834	set	4	160	50

A37

**Floating jaws SRP**, hardened and ground, for workpieces with/without angular and parallelism errors



Item no.	Contents of delivery	Size	Width mm	Height mm
077097	set	2	110	38
077098	set	3	135	46
077099	set	4	160	56

A37

**Stepped top jaw ASB**, for stationary jaw



Item no.	Contents of delivery	Size	Width mm	Height mm
153403	piece	2	113	19
153405	piece	3	135	22
153407	piece	4	160	25

A37

**Stepped top jaw ASB**, for movable jaw



Item no.	Contents of delivery	Size	Width mm	Height mm
153404	piece	2	113	19
153406	piece	3	135	22
153408	piece	4	160	25

A37

**Floating jaw horizontal PEB**, for clamping non-parallel workpieces



Item no.	Contents of delivery	Size	Width mm	Height mm	Thickness mm
156190	piece	92	113	32	36
156191	piece	125	135	40	40
156192	piece	160	160	50	45

Accessories NC power vices RBAW

# Accessories RBAW

A37

**Hand crank**, turnable handle, hexagon socket

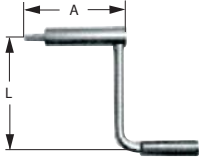

Item no.	Contents of delivery	Size	Hexagon	A mm	L mm
134499	piece	4	12	117	90

A37

**Single clamp SPE**, for mounting vices on end and on the base



Item no.	Contents of delivery	T-slot	Thread
149121	piece	12	M10x50
149122	piece	14	M12x55
149123	piece	16	M12x60
149124	piece	18	M16x60
155722	piece	20	M16x65
151507	piece	22	M16x65

A37

**Fixed slot nuts NTS**, hardened and ground, with fixing screw



Item no.	Contents of delivery	Size	Length mm
014823	set	20x12	22
014825	set	20x14	25
014827	set	20x16	25
014829	set	20x18	25
014831	set	20x20	22
014833	set	20x22	32

# General accessories

A37  
**Dual clamp DSP**, for mutual support in the case of front-sided set-up in pairs



Item no.	Contents of delivery
149125	piece

A37  
**Single clamp SPE**, for mounting vices on end and on the base



Item no.	Contents of delivery	T-slot	Thread
149121	piece	12	M10x50
149122	piece	14	M12x55
149123	piece	16	M12x60
149124	piece	18	M16x60
155722	piece	20	M16x65
151507	piece	22	M16x65

A37  
**Work locator WSA**, universally adjustable, for screwing onto the NC-compact vice or machine vice, connecting thread M12



Item no.	Contents of delivery
320400	piece

A37  
**Work locator WSA**, universally adjustable, for fastening to the machine table (size 14 T-slot) or for screwing onto the NC-compact vice / machine vice (M12)



Item no.	Contents of delivery
320401	piece

A37  
**Precision vice locator PSA**, universally adjustable, for screwing onto the NC-compact vice or machine vice, connecting thread M12



Item no.	Contents of delivery
681192	piece

A37  
**Fixed slot nuts NTS**, hardened and ground, with fixing screw



Item no.	Contents of delivery	Size	Length mm
014823	set	20x12	22
014825	set	20x14	25
014827	set	20x16	25
014829	set	20x18	25
014831	set	20x20	22
014833	set	20x22	32

General accessories NC power vices