



APPLICATION

For universal use on milling machines and machining centers.

TYPE

Manual clamping system with power amplifier.

CUSTOMER BENEFITS

- ⊕ Stepped clamping force presetting
- ⊕ High precision thanks to precise jaw guides
- ⊕ Fast clamping range adjustment via bolt system
- ⊕ Optimal coolant and chip drain
- ⊕ High wear-resistance thanks to hardened jaw guides
- ⊕ Use without force amplification possible for sensitive clamping

TECHNICAL FEATURES

- Base with grooves for exact fixation on the machine table
- Use on rotary plate with graduation
- Set-up option with clamping claws
- Encapsulated spindle

A10

RB-K, with SGN normal jaws and hand crank

Item no.	179075	179076	179077	179078	179079
Size	1	2	3	4	5
Jaw width A mm	92	113	135	160	200
Clamping capacity B mm	100	170	220	310	350
C mm	31,6	31,6	39,6	49,6	66,6
D mm	490	583	679	817	1022
E mm	91	97	112	133	171
F mm	310	390	468	574	685
G±0,02 mm	59	65,5	72,5	83,5	104,5
H mm	50	55	70	80	90
J mm	218	236,5	262	298	375
K mm	160	160	200	240	280
O mm	115	160	180	220	230
P mm	90	90	90	90	160
Q mm	13	13	13	17	21
S mm	100	100	135	180	180
Y mm	12	12	16	16	20
a mm	63	63	80	100	140
b mm	13,6	13,6	15,6	19,6	23
c	M6	M6	M8	M8	M10
d mm	12	12	13	13	16
Clamping force kN	25	30	40	50	100
Weight kg	15,5	24	39	60	112

RB-K



Machine vices
Orange Line

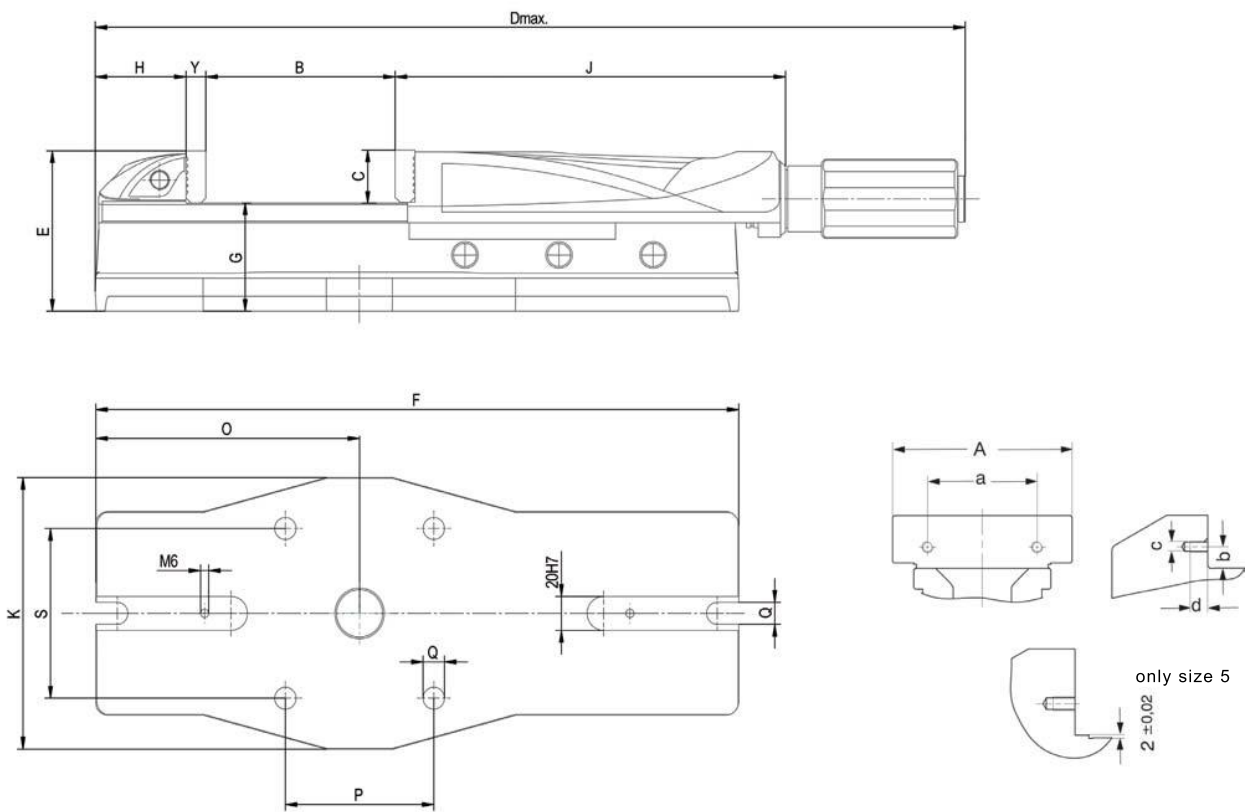

Accessories RB-K

A37
Draw-down jaws RNG, with two permanent magnets



Item no.	Contents of delivery	Size	Width mm	Height mm
155237	set	1	92	32
155238	set	2	110	32
155239	set	3	135	40
155240	set	4	160	50
155241	set	5	200	67

A37
Standard insert RNS, held by two permanent magnets



Item no.	Contents of delivery	Size	Width mm	C mm	Y mm
155242	set	1	92	32	21
155243	set	2	110	32	21
155244	set	3	135	40	26
155245	set	4	160	50	30
155246	set	5	200	67	36

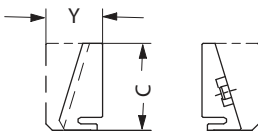

A37
Standard insert, finely checkered RNSf, held by two permanent magnets



Item no.	Contents of delivery	Size	Width mm	C mm	Y mm
163270	set	1	92	32	21
163271	set	2	110	32	21
163272	set	3	135	40	26
163273	set	4	160	50	30
163274	set	5	200	67	36

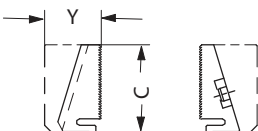

A37
Claw insert RNK, held by two permanent magnets



Item no.	Contents of delivery	Size	Width mm	C mm	Y mm
155247	set	1	92	32	21
155248	set	2	110	32	21
155249	set	3	135	40	26
155250	set	4	160	50	30
155251	set	5	200	67	36

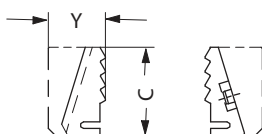

Accessories RB-K

A37
Insert with round clamping shoulder RNR, held by two permanent magnets



Item no.	Contents of delivery	Size	Width mm	C mm	Y mm
155252	set	1	92	32	21
155253	set	2	110	32	21
155254	set	3	135	40	26
155255	set	4	160	50	30
155256	set	5	200	67	36

A37
Draw-down jaws STB, for parallel, angular or flat workpieces, hardened and ground



Item no.	Contents of delivery	Size	Width mm	Height mm
134826	set	2	110	32
134830	set	3	135	40
134834	set	4	160	50
134854	set	5	200	67

A37
Floating jaws SRP, hardened and ground, for workpieces with/without angular and parallelism errors



Item no.	Contents of delivery	Size	Width mm	Height mm
077097	set	2	110	38
077098	set	3	135	46
077099	set	4	160	56
141791	set	5	200	68

A37
Draw-down jaws SNF, with spring plate, hardened and ground



Item no.	Contents of delivery	Size	Width mm	Height mm
077104	set	2	113	31,6
077105	set	3	135	39,6
077106	set	4	160	49,6
141794	set	5	200	64,6

A37
Normal jaw SGN, one side smooth, one side grooved, both sides ground



Item no.	Contents of delivery	Size	Width mm	Height mm
152752	piece	1	92	31,6
152753	piece	2	113	31,6
152754	piece	3	135	39,6
152755	piece	4	160	49,6
152756	piece	5	200	64,6

Accessories RB-K

A37

Normal jaw finely checkered SGNf, reversible, to increase the specific contact pressure (higher holding forces), one side finely checkered, one side longitudinally grooved



Item no.	Contents of delivery	Size	Width mm	Height mm
163218	piece	1	92	31,6
156195	piece	2	113	31,6
156196	piece	3	135	39,6
156197	piece	4	160	49,6
156199	piece	5	200	64,6

A37

V-jaw SPR, with vertically and horizontally ground-in prisms, hardened, for combination with SGN, only suitable for double clamping



Item no.	Contents of delivery	Size	Width mm	Height mm	Chuck capacity mm	
					Horizontal	Vertical
128770	piece	1	92	31,6	3-13	5-32
082362	piece	2	113	31,6	3-13	5-32
082363	piece	3	135	39,6	4-20	6-40
082364	piece	4	160	49,6	5-29	7-48
129734	piece	5	200	64,6	6-37	8-56

A37

Normal jaw SGNA, with movable workpiece stop, hardened and ground, only suitable for double clamping



Item no.	Contents of delivery	Size	Width mm	Height mm
150739	piece	2	113	31,6
150740	piece	3	135	39,6
150741	piece	4	160	49,6

A37

Floating jaw horizontal PEB, for clamping non-parallel workpieces



Item no.	Contents of delivery	Size	Width mm	Height mm	Thickness mm
156190	piece	2	113	32	36
156191	piece	3	135	40	40
156192	piece	4	160	50	45

A37

Hand crank, turnable handle, hexagon socket

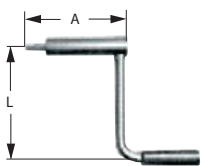

Item no.	Contents of delivery	Size	Hexagon	A	L
134593	piece	1/2	12	48	80
134198	piece	3	12	60	90
134499	piece	4	12	117	90
134600	piece	5	14	104	160

Accessories RB-K

A37
Hydraulic unit HDE

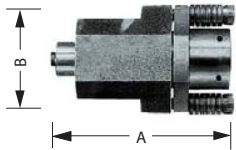

Item no.	Contents of delivery	Size	A	B
094170	piece	1	102	56
226502	piece	2	109	62
226503	piece	3	114	70
226504	piece	4	115	70
226505	piece	5	147	98

A37
Spindle, complete



Item no.	Contents of delivery	Size	L
134185	piece	1	91
134186	piece	2	99
134187	piece	3	116
134188	piece	4	151
134189	piece	5	182

A37
Standard rotation plate DP, with fixing screws and T-slot nuts, ground contact edge, graduation



Item no.	Size	External Ø mm	Height	Center Ø	Weight
082441	2	242	30	28	7,5
082442	3	280	30	28	11
082443	4	340	34	28	18

A37
Universal rotation plate DP, with fixing screws and T-slot nuts, ground contact edge, graduation



Item no.	Size	External Ø mm	Height	Center Ø	Weight
090854	5	420	40	28	23

Machine vices
Orange Line