

ABSIS-C



APPLICATION

Internal clamping of round workpieces. Turning, milling, grinding and tothing operations, as well as for balancing and measuring.
 Rotational machining with adaptation to CAPTIS-D, CAPTIS-A.
 Stationary machining with adaptation to CAPTIS-MS.
 Ideal for clamping in through-holes.

TYPE

Manual with adaptation to CAPTIS-MS.
 Force-actuation with adaptation to CAPTIS-D, CAPTIS-A.

CUSTOMER BENEFITS

- ⊕ Short setup and non-productive times thanks to great expansion of the segment sleeves
- ⊕ Vibration damping due to high vulcanized rubber component of the clamping sleeves
- ⊕ Sturdy clamping of the workpiece thanks to axial tension against the workpiece stop
- ⊕ Fast change of segment sleeves thanks to central clamping screw
- ⊕ High concentricity, axial run-out and repeatability
- ⊕ Innovative quick-change function for fast retrofitting from external to internal clamping

TECHNICAL FEATURES

- Identical change parts as for standard segment clamping mandrel ABSIS

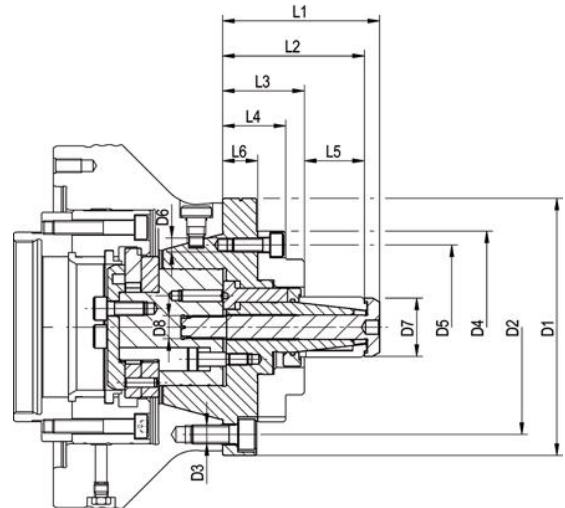

C 15
 ABSIS-C clamping mandrel

Size	ABSIS 00	ABSIS 00	ABSIS 00	ABSIS 00	ABSIS 01	ABSIS 01	ABSIS 01	ABSIS 01	ABSIS 02	ABSIS 02	ABSIS 02	ABSIS 03
Segment clamping mandrel	1286200	1286201	1286202	1286203	1286204	1286205	1286206	1286207	1286208	1286209	1286210	1286211
For	CAPTIS 32	CAPTIS 42	CAPTIS 52	CAPTIS 65	CAPTIS 32	CAPTIS 42	CAPTIS 52	CAPTIS 65	CAPTIS 42	CAPTIS 52	CAPTIS 65	CAPTIS 65
D Min-Ø unclamped from	19,7	19,7	19,7	19,7	25,7	25,7	25,7	25,7	35,7	35,7	35,7	50,7
D Min-Ø unclamped to	27,7	27,7	27,7	27,7	38,7	38,7	38,7	38,7	54,7	54,7	54,7	81,7
D1	88	108	110	128	88	108	110	128	110	110	128	128
D2	70	90	92	110	70	90	92	110	90	92	110	110
D3	3x M8	3x M8	3x M8	3x M8	3x M8	3x M8	3x M8	3x M8	3x M8	3x M8	3x M8	3x M8
D4	82	82	82	82	82	82	82	82	97	97	97	102
D5	70	70	70	70	70	70	70	70	84	84	84	89
D6	3x M6	3x M6	3x M6	3x M6	3x M6	3x M6	3x M6	3x M6	3x M6	3x M6	3x M6	3x M6
D7	19	19	19	19	25	25	25	25	35	35	35	48
D8	M6x0,75	M6x0,75	M6x0,75	M6x0,75	M10x1	M10x1	M10x1	M10x1	M14x1	M14x1	M14x1	M18x1
L1	62,2	62,2	62,2	62,2	67,2	67,2	67,2	67,2	95,2	95,2	95,2	105,2
L2	56,7	56,7	56,7	56,7	60,7	60,7	60,7	60,7	85	85	85	93,2
L3	35	35	35	35	35	35	35	35	42,5	42,5	42,5	44,5
L4	25	25	25	25	27	27	27	27	30,25	30,25	30,25	31,5
L5	21,7	21,7	21,7	21,7	25,7	25,7	25,7	25,7	42,5	42,5	42,5	48,7
L6	15	15	15	15	15	15	15	15	18	18	18	18,5

Collet chuck system
CAPTIS