

Accessories KFR / MFR

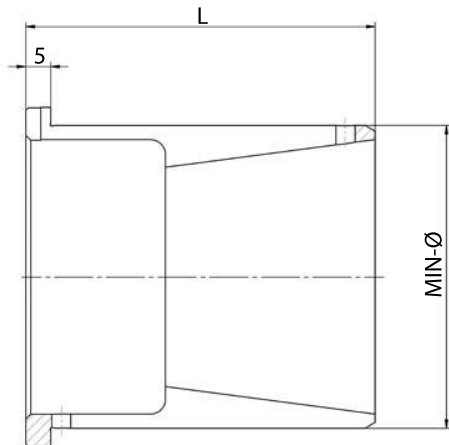

C 18
Clamping sleeve Type R - standard design (not vulcanized)

	00	01	02	03	04	05	06	07	08	09	10	11	12
For size	00	01	02	03	04	05	06	07	08	09	10	11	12
Expansion in Ø mm	0,5	0,5	0,5	0,5	0,5	0,5	1	1	1	1	1	1	1
Total length L	32	40	40	40	55	55	70	70	70	78	78	78	78
Min-Ø mm	14,2	19,7	25,2	35,2	40,2	50,2	60,7	70,7	80,7	100,7	100,7	110,7	120,7
Clamping sleeve	1015500	1015513	1015526	1015548	1015560	1015582	1015605 ▲	1015617 ▲	1015629 ▲	1015651 ▲	1015653 ▲	1015665 ▲	1015677 ▲
Work stop	893830	893836	893842	893852	893857	893867	893878	893888	893897	893916	893917	893927	893937
Min-Ø mm	14,7	20,2	25,7	35,7	40,7	50,7	61,7	71,7	81,7	90,7	101,7	111,7	121,7
Clamping sleeve	1015501	1015514	1015527	1015549	1015561	1015583	1015606 ▲	1015618 ▲	1015630 ▲	1015641 ▲	1015654 ▲	1015666 ▲	1015678 ▲
Work stop	893830	893836	893842	893852	893857	893867	893879	893889	893898	893907	893918	893928	893938
Min-Ø mm	15,2	20,7	26,2	36,2	41,2	51,2	62,7	72,7	82,7	91,7	102,7	112,7	122,7
Clamping sleeve	1015502	1015515	1015528	1015550	1015562	1015584	1015607 ▲	1015619 ▲	1015631 ▲	1015642 ▲	1015655 ▲	1015667 ▲	1015679 ▲
Work stop	893830	893837	893842	893852	893857	893867	893880	893890	893899	893908	893919	893929	893939
Min-Ø mm	15,7	21,2	26,7	36,7	41,7	51,7	63,7	73,7	83,7	92,7	103,7	113,7	123,7
Clamping sleeve	1015503	1015516	1015529	1015551	1015563	1015585	1015608 ▲	1015620 ▲	1015632 ▲	1015643 ▲	1015656 ▲	1015668 ▲	1015680 ▲
Work stop	893831	893837	893843	893853	893858	893868	893881	893891	893900	893909	893920	893930	893940
Min-Ø mm	16,2	21,7	27,2	37,2	42,2	52,2	64,7	74,7	84,7	93,7	104,7	114,7	124,7
Clamping sleeve	1015504	1015517	1015530	1015552	1015564	1015586	1015609 ▲	1015621 ▲	1015633 ▲	1015644 ▲	1015657 ▲	1015669 ▲	1015681 ▲
Work stop	893831	893838	893843	893853	893858	893868	893882	893892	893901	893910	893921	893931	893941
Min-Ø mm	16,7	22,2	27,7	37,7	42,7	52,7	65,7	75,7	85,7	94,7	105,7	115,7	125,7
Clamping sleeve	1015505	1015518	1015531	1015553	1015565	1015587	1015610 ▲	1015622 ▲	1015634 ▲	1015645 ▲	1015658 ▲	1015670 ▲	1015682 ▲
Work stop	893832	893838	893844	893854	893859	893869	893883	893893	893902	893911	893922	893932	893942
Min-Ø mm	17,2	22,7	28,2	38,2	43,2	53,2	66,7	76,7	86,7	95,7	106,7	116,7	126,7
Clamping sleeve	1015506	1015519	1015532	1015554	1015566	1015588	1015611 ▲	1015623 ▲	1015635 ▲	1015646 ▲	1015659 ▲	1015671 ▲	1015683 ▲
Work stop	893832	893839	893844	893854	893859	893869	893884	893894	893903	893912	893923	893933	893943
Min-Ø mm	17,7	23,2	28,7	38,7	43,7	53,7	67,7	77,7	87,7	96,7	107,7	117,7	127,7
Clamping sleeve	1015507	1015520	1015533	1015555	1015567	1015589	1015612 ▲	1015624 ▲	1015636 ▲	1015647 ▲	1015660 ▲	1015672 ▲	1015684 ▲
Work stop	893833	893839	893845	893855	893860	893870	893885	893895	893904	893913	893924	893934	893944
Min-Ø mm	18,2	23,7	29,2	39,2	44,2	54,2	68,7	78,7	88,7	97,7	108,7	118,7	128,7
Clamping sleeve	1015508	1015521	1015534	1015556	1015568	1015590	1015613 ▲	1015625 ▲	1015637 ▲	1015648 ▲	1015661 ▲	1015673 ▲	1015685 ▲
Work stop	893833	893840	893845	893855	893860	893870	893886	893947	893905	893914	893925	893935	893945
Min-Ø mm	18,7	24,2	29,7	39,7	44,7	54,7	69,7	79,7	89,7	98,7	109,7	119,7	129,7
Clamping sleeve	1015509	1015522	1015535	1015557	1015569	1015591	1015614 ▲	1015626 ▲	1015638 ▲	1015649 ▲	1015662 ▲	1015674 ▲	1015686 ▲
Work stop	893834	893840	893846	893856	893861	893871	893887	893896	893906	893915	893926	893936	893946
Min-Ø mm	19,2	24,7	30,2	40,2	45,2	55,2	70,7	80,7	90,7	99,7	110,7	120,7	130,7
Clamping sleeve	1015510	1015523	1015536	1015558	1015570	1015592	1015615 ▲	1015627 ▲	1015639 ▲	1015650 ▲	1015663 ▲	1015675 ▲	1015687 ▲
Work stop	893834	893841	893846	893856	893861	893871	893887	893896	893906	893916	893926	893936	893946
Min-Ø mm	19,7	25,2	30,7		45,7	55,7							
Clamping sleeve	1015511	1015524	1015537		1015571	1015593							
Work stop	893835	893841	893847		893862	893872							
Min-Ø mm			31,2		46,2	56,2							

Different chucking Ø and profiled clamping sleeves on request

Accessories KFR / MFR

Accessories KFR / MFR

C 18

Clamping sleeve Type R - standard design (not vulcanized)

For size	00	01	02	03	04	05	06	07	08	09	10	11	12
Expansion in Ø mm	0,5	0,5	0,5	0,5	0,5	0,5	1	1	1	1	1	1	1
Total length L	32	40	40	40	55	55	70	70	70	78	78	78	78
Clamping sleeve			1015538		1015572	1015594							
Work stop			893847		893862	893872							
Min-Ø mm			31,7		46,7	56,7							
Clamping sleeve			1015539		1015573	1015595							
Work stop			893848		893863	893873							
Min-Ø mm			32,2		47,2	57,2							
Clamping sleeve			1015540		1015574	1015596							
Work stop			893848		893863	893873							
Min-Ø mm			32,7		47,7	57,7							
Clamping sleeve			1015541		1015575	1015597							
Work stop			893849		893864	893874							
Min-Ø mm			33,2		48,2	58,2							
Clamping sleeve			1015542		1015576	1015598							
Work stop			893849		893864	893874							
Min-Ø mm			33,7		48,7	58,7							
Clamping sleeve			1015543		1015577	1015599							
Work stop			893850		893865	893875							
Min-Ø mm			34,2		49,2	59,2							
Clamping sleeve			1015544		1015578	1015600							
Work stop			893850		893865	893875							
Min-Ø mm			34,7		49,7	59,7							
Clamping sleeve			1015545		1015579	1015601							
Work stop			893851		893866	893876							
Min-Ø mm			35,2		50,2	60,2							
Clamping sleeve			1015546		1015580	1015602							
Work stop			893851		893866	893876							
Min-Ø mm						60,7							
Clamping sleeve						1015603							
Work stop						893877							

Different chucking Ø and profiled clamping sleeves on request

Accessories KFR / MFR

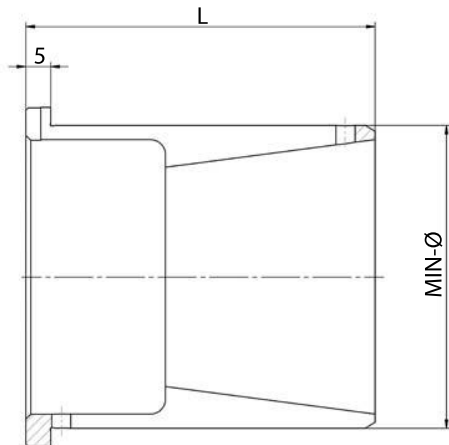

C 18
Clamping sleeve Type R - vulcanized

For size	00	01	02	03	04	05	06	07	08	09	10	11	12
Expansion in Ø mm	0,5	0,5	0,5	0,5	0,5	0,5	1	1	1	1	1	1	1
Total length L	32	40	40	40	55	55	70	70	70	78	78	78	78
Min-Ø mm	14,2	19,7	25,2	35,2	40,2	50,2	60,7	70,7	80,7	100,7	100,7	110,7	120,7
Clamping sleeve	1015700	1015713	1015726	1015748	1015760	1015782	1015805 ▲	1015817 ▲	1015829 ▲	1015851 ▲	1015853 ▲	1015865 ▲	1015877 ▲
Work stop	893830	893836	893842	893852	893857	893867	893878	893888	893897	893916	893917	893927	893937
Min-Ø mm	14,7	20,2	25,7	35,7	40,7	50,7	61,7	71,7	81,7	90,7	101,7	111,7	121,7
Clamping sleeve	1015701	1015714	1015727	1015749	1015761	1015783	1015806 ▲	1015818 ▲	1015830 ▲	1015841 ▲	1015854 ▲	1015866 ▲	1015878 ▲
Work stop	893830	893836	893842	893852	893857	893867	893879	893889	893898	893907	893918	893928	893938
Min-Ø mm	15,2	20,7	26,2	36,2	41,2	51,2	62,7	72,7	82,7	91,7	102,7	112,7	122,7
Clamping sleeve	1015702	1015715	1015728	1015750	1015762	1015784	1015807 ▲	1015819 ▲	1015831 ▲	1015842 ▲	1015855 ▲	1015867 ▲	1015879 ▲
Work stop	893830	893837	893842	893852	893857	893867	893880	893890	893899	893908	893919	893929	893939
Min-Ø mm	15,7	21,2	26,7	36,7	41,7	51,7	63,7	73,7	83,7	92,7	103,7	113,7	123,7
Clamping sleeve	1015703	1015716	1015729	1015751	1015763	1015785	1015808 ▲	1015820 ▲	1015832 ▲	1015843 ▲	1015856 ▲	1015868 ▲	1015880 ▲
Work stop	893831	893837	893843	893853	893858	893868	893881	893891	893900	893909	893920	893930	893940
Min-Ø mm	16,2	21,7	27,2	37,2	42,2	52,2	64,7	74,7	84,7	93,7	104,7	114,7	124,7
Clamping sleeve	1015704	1015717	1015730	1015752	1015764	1015786	1015809 ▲	1015821 ▲	1015833 ▲	1015844 ▲	1015857 ▲	1015869 ▲	1015881 ▲
Work stop	893831	893837	893843	893853	893858	893868	893882	893892	893901	893910	893921	893931	893941
Min-Ø mm	16,7	22,2	27,7	37,7	42,7	52,7	65,7	75,7	85,7	94,7	105,7	115,7	125,7
Clamping sleeve	1015705	1015718	1015731	1015753	1015765	1015787	1015810 ▲	1015822 ▲	1015834 ▲	1015845 ▲	1015858 ▲	1015870 ▲	1015882 ▲
Work stop	893832	893838	893844	893854	893859	893869	893883	893893	893902	893911	893922	893932	893942
Min-Ø mm	17,2	22,7	28,2	38,2	43,2	53,2	66,7	76,7	86,7	95,7	106,7	116,7	126,7
Clamping sleeve	1015706	1015719	1015732	1015754	1015766	1015788	1015811 ▲	1015823 ▲	1015835 ▲	1015846 ▲	1015859 ▲	1015871 ▲	1015883 ▲
Work stop	893832	893838	893844	893854	893859	893869	893884	893894	893903	893912	893923	893933	893943
Min-Ø mm	17,7	23,2	28,7	38,7	43,7	53,7	67,7	77,7	87,7	96,7	107,7	117,7	127,7
Clamping sleeve	1015707	1015720	1015733	1015755	1015767	1015789	1015812 ▲	1015824 ▲	1015836 ▲	1015847 ▲	1015860 ▲	1015872 ▲	1015884 ▲
Work stop	893833	893839	893845	893855	893860	893870	893885	893895	893904	893913	893924	893934	893944
Min-Ø mm	18,2	23,7	29,2	39,2	44,2	54,2	68,7	78,7	88,7	97,7	108,7	118,7	128,7
Clamping sleeve	1015708	1015721	1015734	1015756	1015768	1015790	1015813 ▲	1015825 ▲	1015837 ▲	1015848 ▲	1015861 ▲	1015873 ▲	1015885 ▲
Work stop	893833	893839	893845	893855	893860	893870	893886	893947	893905	893914	893925	893935	893945
Min-Ø mm	18,7	24,2	29,7	39,7	44,7	54,7	69,7	79,7	89,7	98,7	109,7	119,7	129,7
Clamping sleeve	1015709	1015722	1015735	1015757	1015769	1015791	1015814 ▲	1015826 ▲	1015838 ▲	1015849 ▲	1015862 ▲	1015874 ▲	1015886 ▲
Work stop	893834	893840	893846	893856	893861	893871	893887	893896	893906	893915	893926	893936	893946
Min-Ø mm	19,2	24,7	30,2	40,2	45,2	55,2	70,7	80,7	90,7	99,7	110,7	120,7	130,7
Clamping sleeve	1015710	1015723	1015736	1015758	1015770	1015792	1015815 ▲	1015827 ▲	1015839 ▲	1015850 ▲	1015863 ▲	1015875 ▲	1015887 ▲
Work stop	893834	893840	893846	893856	893861	893871	893887	893896	893906	893916	893926	893936	893946
Min-Ø mm	19,7	25,2	30,7		45,7	55,7							
Clamping sleeve	1015711	1015724	1015737		1015771	1015793							
Work stop	893835	893841	893847		893862	893872							
Min-Ø mm			31,2		46,2	56,2							
Clamping sleeve			1015738		1015772	1015794							
Work stop			893847		893862	893872							
Min-Ø mm			31,7		46,7	56,7							

Different chucking Ø and profiled clamping sleeves on request

Accessories KFR / MFR

Accessories KFR / MFR

C 18

Clamping sleeve Type R - vulcanized

For size	00	01	02	03	04	05	06	07	08	09	10	11	12
Expansion in Ø mm	0,5	0,5	0,5	0,5	0,5	0,5	1	1	1	1	1	1	1
Total length L	32	40	40	40	55	55	70	70	70	78	78	78	78
Clamping sleeve			1015739		1015773	1015795							
Work stop			893848		893863	893873							
Min-Ø mm			32,2		47,2	57,2							
Clamping sleeve			1015740		1015774	1015796							
Work stop			893848		893863	893873							
Min-Ø mm			32,7		47,7	57,7							
Clamping sleeve			1015741		1015775	1015797							
Work stop			893849		893864	893874							
Min-Ø mm			33,2		48,2	58,2							
Clamping sleeve			1015742		1015776	1015798							
Work stop			893849		893864	893874							
Min-Ø mm			33,7		48,7	58,7							
Clamping sleeve			1015743		1015777	1015799							
Work stop			893850		893865	893875							
Min-Ø mm			34,2		49,2	59,2							
Clamping sleeve			1015744		1015778	1015800							
Work stop			893850		893865	893875							
Min-Ø mm			34,7		49,7	59,7							
Clamping sleeve			1015745		1015779	1015801							
Work stop			893851		893866	893876							
Min-Ø mm			35,2		50,2	60,2							
Clamping sleeve			1015746		1015780	1015802							
Work stop			893851		893866	893876							
Min-Ø mm						60,7							
Clamping sleeve						1015803							
Work stop						893877							

Different chucking Ø and profiled clamping sleeves on request

Intermediate flange KFR / MFR



APPLICATION

For adaption of cartridge mandrel KFR/MFR/KFR-SE/MFR-SE or KFS/MFS - on spindle head ISO 702-1 / ISO 702-3 (DIN 55021/55022/55026 and 55027).

TYPE

For KFR/MFR/KFR-SE/MFR-SE or KFS/MFS.

CUSTOMER BENEFITS

- By replacement of the Intermediate flange, one cartridge mandrel can be used on different machines

TECHNICAL FEATURES

Adaptation of mandrel KFR / MFR / KFR-SE / MFR SE or KFS / MFS on spindle head, with or without adjustment, with or without operation of air-conditioning control. Execution according to ISO 702-1 (DIN 55028-A) or ISO 702-3 (DIN 55028-C), in size no. 5, no. 6, no. 8, no. 11 or no. 5, no. 6. Nr. 8 (A5, A6, A8, A11 or C5, C6, C8).

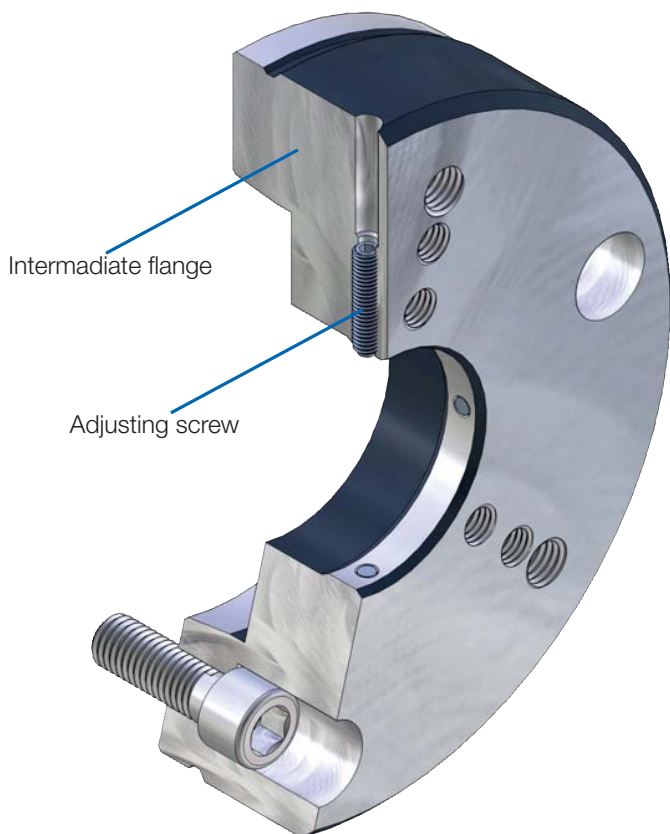

Intermediate flange
KFR / MFR

Accessories KFR / MFR

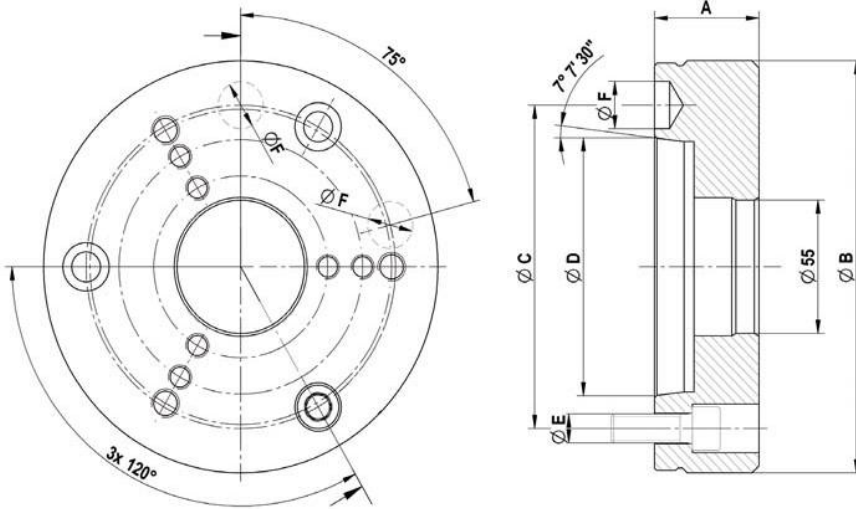

C 18

Intermediate flange ISO 702-1 (DIN 55026/55021) without adjusting screws

	Nr. 5 (A 05)	Nr. 6 (A 06)	Nr. 8 (A 08)	Nr. 11 (A 11)
Intermediate flange	893975	893976	893977	893978 ▲
Design	without air-sensing	without air-sensing	without air-sensing	without air-sensing
Mount-Ø 55	+0,003/+0,001	+0,003/+0,001	+0,003/+0,001	+0,003/+0,001
A mm	45	45	50	50
Ø B	165	170	220	282
Ø C mm	104,8	133,4	171,4	235
Ø D mm	82,563	106,375	139,719	196,869
Ø E	M10	M12	M16	M20
Ø F mm	16,3	19,45	24,2	29,4

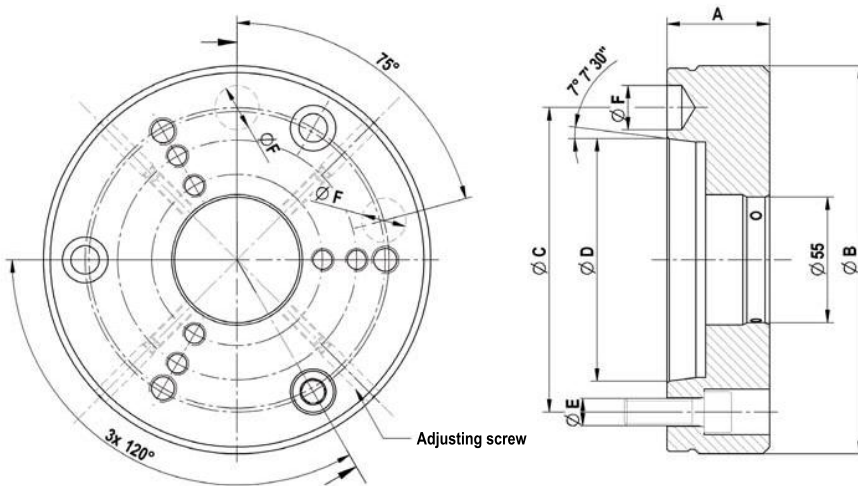

C 18

Intermediate flange ISO 702-1 (DIN 55028) with adjusting screw

	Nr. 5 (A 05)	Nr. 6 (A 06)	Nr. 8 (A 08)
Intermediate flange	893979	893980	893981
Design	without air-sensing	without air-sensing	without air-sensing
Mount-Ø 55	+0,05/+0,04	+0,05/+0,04	+0,05/+0,04
A mm	45	45	50
Ø B	165	170	220
Ø C mm	104,8	133,4	171,4
Ø D mm	82,563	106,375	139,719
Ø E	M10	M12	M16
Ø F mm	16,3	19,45	24,2

Accessories KFR / MFR

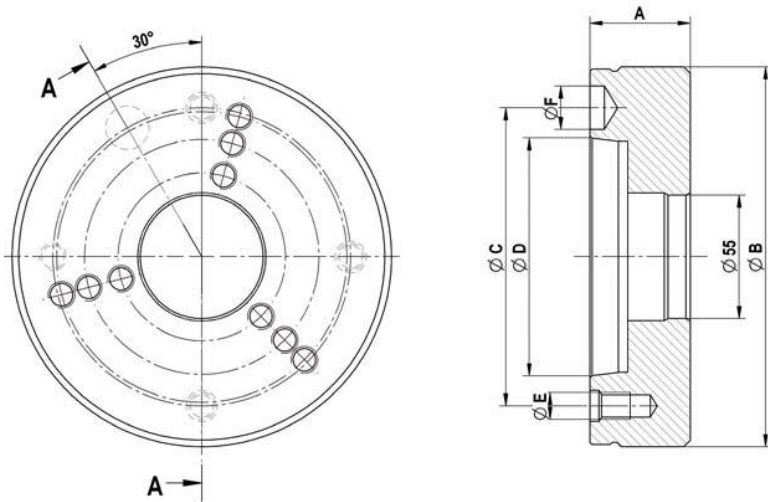

C 18
Intermediate flange ISO 702-3 (DIN 55027/55022) without adjusting screws

	Nr. 5 (C 05)	Nr. 6 (C 06)	Nr. 8 (C 08)
Intermediate flange	893982	893983	893984
Design	without air-sensing	without air-sensing	without air-sensing
Mount-Ø 55	+0,003/+0,001	+0,003/+0,001	+0,003/+0,001
A mm	45	45	50
Ø B	165	170	220
Ø C mm	104,8	133,4	171,4
Ø D mm	82,563	106,375	139,719
Ø E	M 10	M 12	M 16
Ø F mm	16,3	19,45	24,2

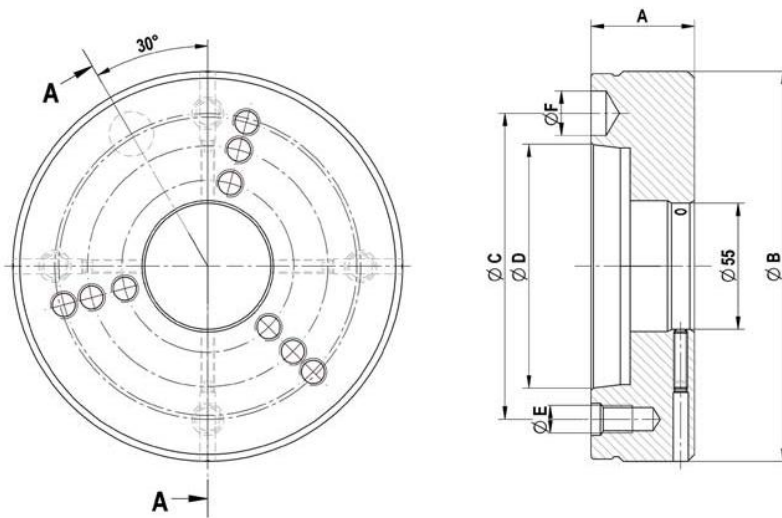

C 18
Intermediate flange ISO 702-3 (DIN 55027/55022) with adjusting screws

	Nr. 5 (C 05)	Nr. 6 (C 06)	Nr. 8 (C 08)
Intermediate flange	893985	893986	893987
Design	without air-sensing	without air-sensing	without air-sensing
Mount-Ø 55	+0,05/+0,04	+0,05/+0,04	+0,05/+0,04
A mm	45	45	50
Ø B	165	170	220
Ø C mm	104,8	133,4	171,4
Ø D mm	82,563	106,375	139,719
Ø E	M 10	M 12	M 16
Ø F mm	16,3	19,45	24,2

Accessories KFR / MFR

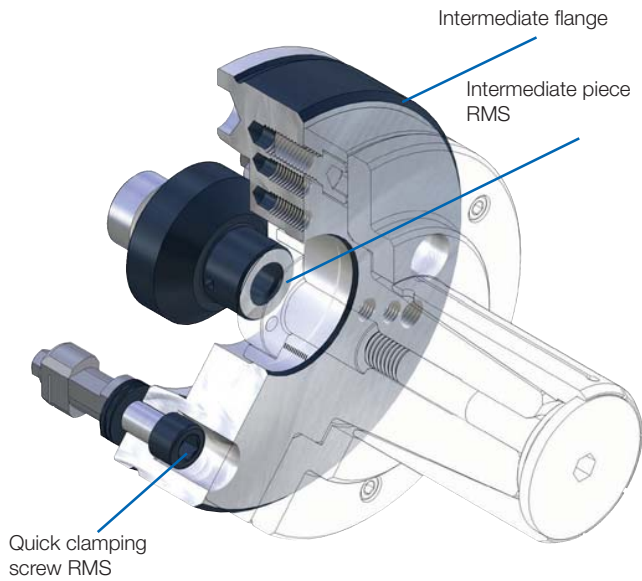

APPLICATION

For manual clamping devices exchange in a minimum of time.

TYPE

Manual quick-change system for clamping devices. Fits KFR/MFR or KFS/MFS. Central lubrication and / or air sensing control possible.

CUSTOMER BENEFITS

- ⌚ Manual clamping devices change in about 30 seconds
- ⌚ High change precision within 0.005 mm
- ⌚ Quick change of different clamping devices with short time, similar to the automatic or semiautomatic clamping devices changing systems

TECHNICAL FEATURES

- Quick-change system suitable due to recording RMS see quick-change system RMS (Product Group 6)
- Corresponds to the guidelines of the Employer's Liability Insurance Association in combination with ROHM safety clamping cylinder OVS and LVS

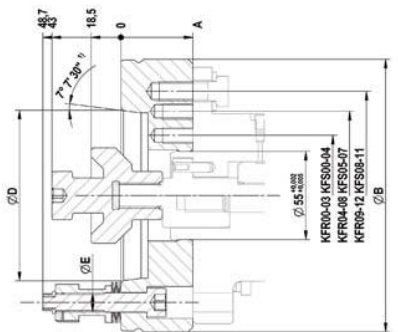
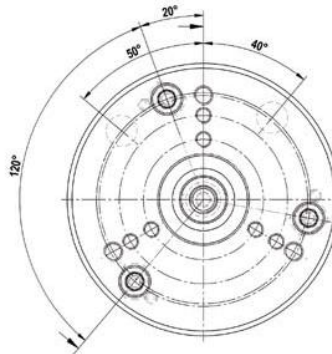
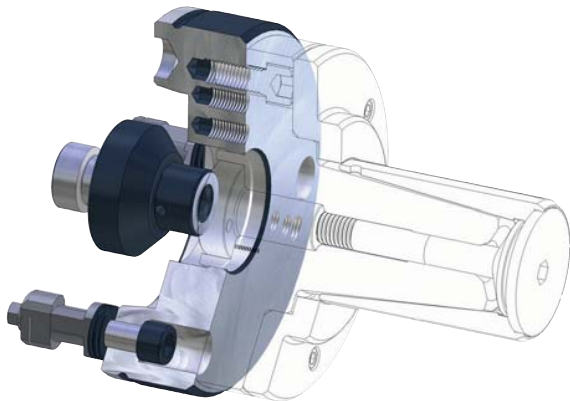

C18
RMS quick-change system, hand-operated for clamping devices

	KK 06	KK 08
RMS - complete (flange incl. quick-clamping screw)	1160026 ▲	1160027 ▲
Adapters RMS	1183310 ▲	1183311 ▲
A	45	50
Ø B	170	220
Ø C	133,4	171,4
Ø D	106,375	139,719
Ø E mm	M12	M16
Ø F mm	55 (+0,003/+0,001)	55 (+0,003/+0,001)