



APPLICATION

For stationary centric clamping of workpieces on milling machines or machining centers.

TYPE

Clamping system consisting of a 3-jaw chuck, including an integrated pneumatic cylinder. Serration 90°.

CUSTOMER BENEFITS

- ③ Compact design
- ③ Large variety of applications is possible by using different clamping jaws
- ③ Centric clamping of round and angular workpieces
- ③ High repeatability thanks to sturdy chuck construction and constant clamping force at same pressure
- ③ Purge air connection possible to prevent contamination

TECHNICAL FEATURES

- Wedge hook system with pneumatic actuation
- Clamping force can be regulated by changing the pressure

Note:

Hydraulic actuation on request

Stationary power chuck SSP

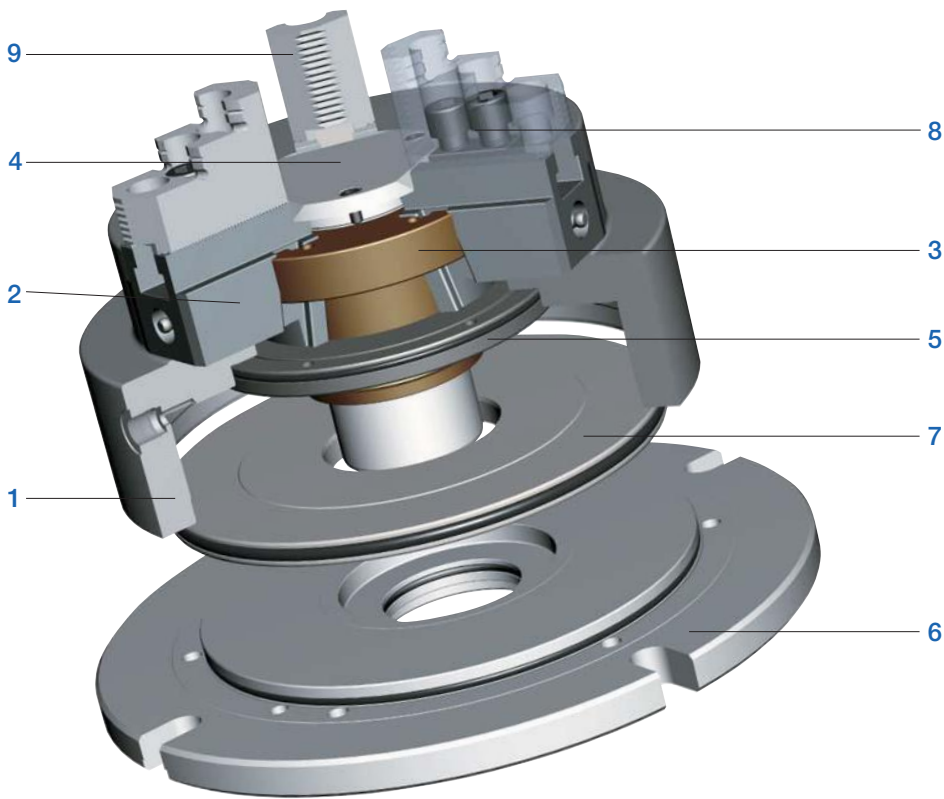

Components:

1. Body
2. Base jaw
3. Piston
4. Protective bushing
5. Intermediate disc
6. Mount
7. Piston disc
8. T-nut
9. Top jaws

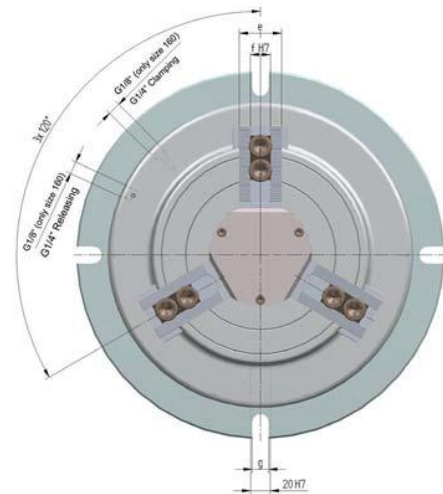
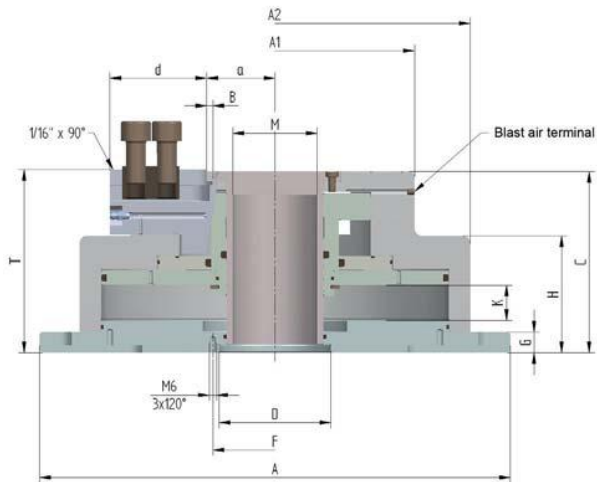

C 15

Stationary power chucks SSP, air operated 3-jaw chucks, without through-hole, serration 1/16" x 90°

Item no.	161505	161506	161507	161508
Size	160	200	250	315
Number of jaws	3	3	3	3
A mm	260	320	380	415
A1 mm	178	205	255	320
A2 mm	210	255	315	350
Jaw travel B mm	4,2	4,2	5	5
C mm	130,5	134	146	156,5
Mount DH6	55	70	90	110
D	M8	M12	M16	M16
F mm	65	80	100	120
G mm	15	17	17	21,5
H mm	84,5	86	94	104,5
Wedge stroke K mm	24	23,8	28,4	28,4
Possible through-hole M mm	38	52	68	90
T mm	131,5	135,5	147,5	158
U	M8	M12	M16	M16
a min.	31,8	41,2	50	61,5
a max.	36	45,4	55	66,5
c mm	15	19	25	25
d mm	54,5	62	78	99
e mm	32	36	44	44
fH7 mm	12	17	21	21
g mm	13	17	17	17
Piston area cm ²	209	323	532	654
Min. operating pressure bar	2	2	2	2
Max. operating pressure bar	8	8	8	8
Max. total clamping force at working pressure - External clamping kN	36 (bei 6 bar)	55 (bei 6 bar)	90 (bei 6 bar)	111 (bei 6 bar)
Max. total clamping force at working pressure - Internal clamping kN	38 (bei 6 bar)	60 (bei 5 bar)	96 (bei 6 bar)	118 (bei 6 bar)
Weight without jaws approx. kg	25	34	54	65

Jaws SSP

C 21
Reversible top jaws, 3-jaw set, hardened serration 90° - material: 16 MnCr 5



Item no.	Chuck Size	Jaw length mm	Jaw height mm	Jaw width mm	Serration
046404	160	56	37,5	26	1/16"x 90°
118522	200	75	49	36	1/16"x 90°
046414	250/315	103,5	58	50	1/16"x 90°

Additionally or later applied, hardened jaws must be ground out in the chuck.

C 21
Soft top jaws, 3-jaw set, can be hardened serration 90° - material: 16 MnCr 5



Item no.	Chuck Size	Jaw length mm	Jaw height mm	Jaw width mm	Serration
046403	160	55	38	26,5	1/16"x 90°
133153	200	75	53	36,5	1/16"x 90°
133154	250	95	54,5	45	1/16"x 90°

C 21
Claw-type jaws, 1 piece, hardened serration 90° - width of the groove 12



Item no.	Chuck Size	Jaw length mm	Jaw height mm	Claw length mm	Serration
144320	160	66	38	52	1/16"x 90°
144321	160	56	38	34	1/16"x 90°
144322	160	66	38	25	1/16"x 90°

C 21
Claw-type jaws, 1 piece, hardened serration 90° - width of the groove 17



Item no.	Chuck Size	Jaw length mm	Jaw height mm	Claw length mm	Serration
137031	200	67	45	53	1/16"x 90°
137032	200	65	45	46	1/16"x 90°
137039	200	55	45	40	1/16"x 90°
137034	200	50	45	31	1/16"x 90°
137035	200	55	45	27	1/16"x 90°
137036	200	65	45	19	1/16"x 90°
137037	200	65	45	26	1/16"x 90°
137038	200	55	45	24	1/16"x 90°
137033	200	55	45	39	1/16"x 90°

C 21
Claw-type jaws, 1 piece, hardened serration 90° - width of the groove 21



Item no.	Chuck Size	Jaw length mm	Jaw height mm	Claw length mm	Serration
137041	250/315	95	50	80	1/16"x 90°
137042	250/315	75	50	60	1/16"x 90°
137043	250/315	60	50	43	1/16"x 90°
137044	250/315	70	50	37	1/16"x 90°
137045	250/315	95	50	25	1/16"x 90°
137046	250/315	80	50	30	1/16"x 90°

Configure your individual clamping jaws online! www.web2product.biz

Accessories SSP

C 15

Extended T-nuts

With screw

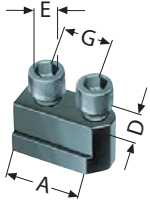

Item no.	Chuck Size	Con- tents of delivery	D mm	E	G mm
1305178	160	piece	12	M8x25	2x15
1305179	200	piece	17	M12x30	19
1305180	250/315	piece	21	M16x35	25

Jaw dimensions SSP

Reversible top jaws UB,
hardened, serration 90°

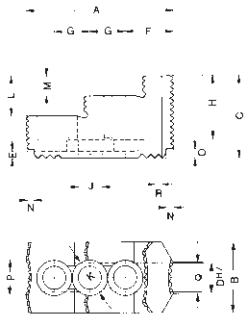

Chuck size	160	200	250/315
Type	538-02	538-04	538-05
Item no. 3-jaw	046404	118522	046414
A	56	75	103,5
B	26	36	50
C	37,5	49	58
DH7	12	17	21
E	3,5	5	5
F	14	21,5	33,5
G	15	19	25
H	29	37,5	45
J	8,4	13	17
K	13,5	19	25
L	20	24	28
M	10	12	14
N	4	6	6
O	4	7,5	6,5
P	5	18	24,5
Q	5	7	22,5
R	1/16"x90°	1/16"x90°	1/16"x90°
Weight/jaw kg	0,170	0,460	1,130

Soft top jaws AB,
Serration 90°

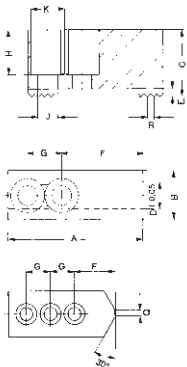

Chuck size	160	200	250/315
Type	538-02	538-03	538-05
Item no. 3-jaw	046403	133152	133154
A	55	66,7	95
B	26,5	36,5	45
C	38	53	54,5
D	12	17	21
E	3,5	5	5
F	31	36	55
G	15	19	25
H	28	43	42,5
J	8,4	13	17
K	13,5	19	25
Q	-	-	-
R	1/16"x90°	1/16"x90°	1/16"x90°
Weight/jaw kg	0,330	0,700	1,400

