

KFG - Power operated angle lever chuck



APPLICATION

Optimally suited for clamping tasks demanding through-hole, flexibility, large strokes and low frictional losses.

TYPE

Angle lever power chuck with cylindrical center mount.
3-jaw version with serration (60°).

CUSTOMER BENEFITS

- ③ Large through-hole
- ③ Large jaw strokes and flexible use can be realized with angle lever system
- ③ High efficiency thanks to low frictional losses (low-hysteresis chuck)
- ③ Long service life - all moving parts are hardened and ground

TECHNICAL FEATURES

- Wide guidance of base jaws
- T-slots in the chuck body
- Lubrication of the jaw guide via easily accessible grease nipples on the axes of the angle lever

Included in the scope of delivery:

Chuck, chuck and jaw mounting screws, wrench, slot nuts, 2 wrenches for the sliding sleeve (without top jaws)

Big range of applications thanks to large through-hole. Suitable for bar machining and other different workpieces. The axial pull force is translated into the radial jaw movement supported by the angle lever.

KFG - Extra large jaw stroke

KFG 3-jaw, large jaw movement, serration 60°

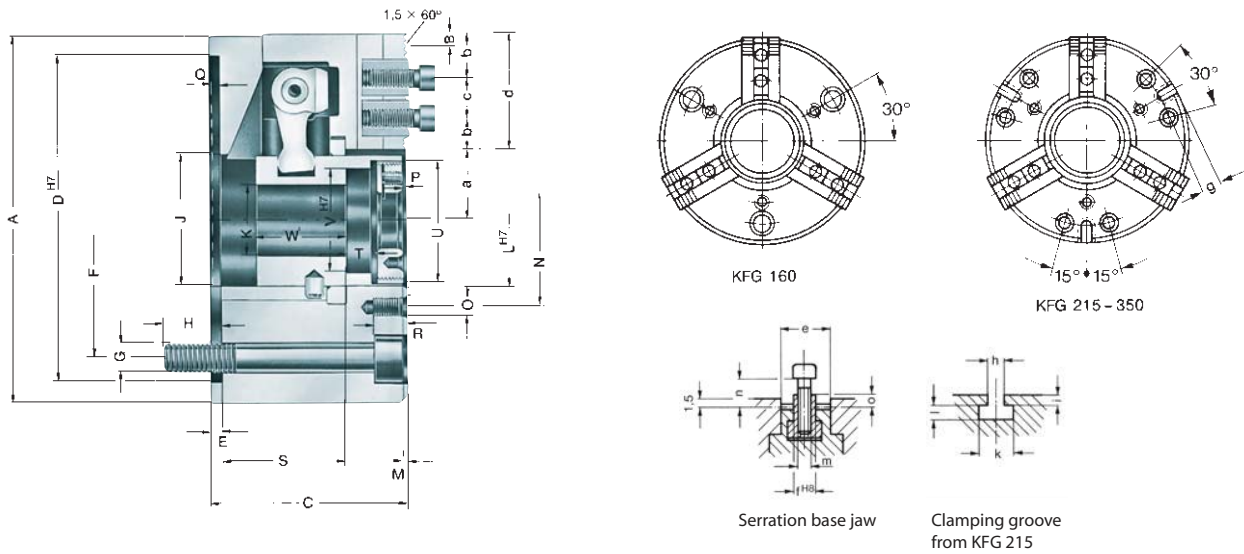

C 15
3-jaw angle lever power chucks KFG, large jaw movement, with serration 60°, cylindrical centre mount

Item no.	020666	020667	020668	020669
Size	160	215	280	350
Number of jaws	3	3	3	3
A mm	160	215	280	350
Jaw travel B mm	16	20	25	25
C mm	79	92	116,2	134,7
DH7	140	190	255	320
E mm	4,2	4,2	5,7	5,7
F mm	104,8	133,4	133,4	171,4
G	3xM10	6xM12	6xM12	6xM16
H mm	20	25	25	35
J mm	54	74	102	135
K mm	26	45,5	66,5	90,5
LH7 mm	66	80	105	140
M mm	2,5	2,5	2,5	2,5
N mm	76	90	120	156
O	M6	M 8	M 8	M 10
P mm	14	16,5	18,7	13,1
Q mm	3,2	3,7	3,2	4,1
R mm	13	15	15	20
S min.	19,8	25,3	28,8	32,9
S max.	39,8	50,3	63,8	77,9
T mm	8	12	18	22
U mm	M46x1,25	M65x1,25	M90x1,25	M112x1,5
VH7 mm	43	62	87	109
W mm	23	29	32	37
a min.	23	31,5	47,5	69,5
a max.	39	51,5	72,5	94,5
b mm	8	10	13	14
c min.	16	20	26	28
c max.	41	46	54	65
d mm	57	66	80	93
e mm	28	35	45	50
fH8 mm	11	14	20	21
g mm	-	35	63	73,5
h mm	-	16	16	22
i mm	-	10	10	15
k mm	-	24	24	35
l mm	-	10	10	17
m mm	M8	M10	M12	M16
n mm	7,5	8,5	13	15
o mm	1,5	1,5	2,5	3
Max. swing top jaws mm	242	295	380	480
Maximum draw bar pull kN	24	33,9	43	52
Max. total clamping force approx. kN	21	30	42	66
Max. admissible speed min-1	3400	2700	1950	1800
Moment of inertia J kgm ²	0,031	0,11	0,425	1,22
Weight without jaws approx. kg	9,3	17	41	75
Actuating cylinders (recommended)	OVS-105 / SZS-37/70	OVS-130 / SZS-46/103	OVS-150 / SZS-67/150	OVS-150 / SZS-86/200

Jaws KFG

C 21

Reversible top jaws, 3-jaw set, hardened serration 60° - material: 16 MnCr 5



Item no.	Chuck Size	Jaw length mm	Jaw height mm	Jaw width mm	Serration
046410	160	62	37,5	26	1,5 x 60°
046412 ¹⁾	215	81	52,5	36	1,5 x 60°
046416	280	96	54	44,5	1,5 x 60°
046422	350	112	61	49,5	1,5 x 60°

¹⁾ Lowered to 34 mm in the serration area

Reversible top jaws UB: Ground out on the associated chuck at extra charge

C 21

Soft top jaws, 3-jaw set, can be hardened serration 60° - material: 16 MnCr 5



Item no.	Chuck Size	Jaw length mm	Jaw height mm	Jaw width mm	Serration
046409	160	66,7	43	30,5	1,5 x 60°
046411	215	88,9	53	36,5	1,5 x 60°
046415	280	88,9	54,5	45	1,5 x 60°
046421	350	120	80	50	1,5 x 60°

Accessories KFG

C 15

T-nuts

with screw, for SV 1,5" x 60°

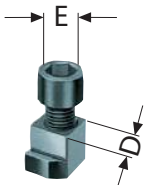

Item no.	Chuck Size	Contents of delivery	D mm	E
1305174	160	piece	11	M8x18
1305175	215	piece	14	M10x20
1305176	280	piece	20	M12x30
1305177	350	piece	21	M16x35

Jaw dimensions und chucking capacities KFG

Reversible top jaws UB,
hardened, serration 60°,
material 16MnCr5

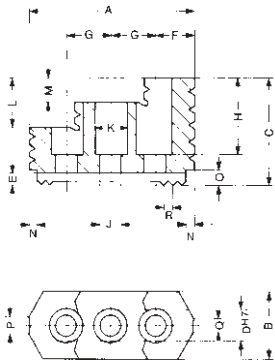

Chuck size	160	215	280	350
Type	530-05	530-07	530-09	530-12
Item no. 3-jaw	046410	046412	046416	046422
A	62	81	96	112
B	26	36 1)	44,5	49,5
C	37,5	52,5	54	61
D	11	14	20	21
E	3,5	5	5	5,5
F	17,5	25	30	27
G	16,5	21	26	33
H	29	41	41	47,5
J	8,4	10,5	13	17
K	13,5	16,5	19	25
L	20	24	24	30
M	10	12	12	15
N	4	5	5	6,5
O	4	7	7	7
P	5	10	10	13
Q	5	5	5	13
R	1,5 x 60°	1,5 x 60°	1,5 x 60°	1,5 x 60°
Weight/jaw kg	0,215	0,600	0,750	1,550

1) Near the serration reduced to 34 mm
Reversible top jaws: ground to finished size at surcharge

Soft top jaws AB,
material 16MnCr5

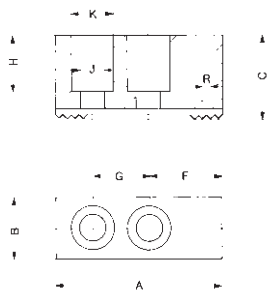

Chuck size	160	215	280	350
Type	530-05	530-07	530-09	530-12
Item no. 3-jaw	046409	046411	046415	046421
A	66,7	88,9	88,9	120
B	30,5	36,5	45	50
C	43	53	54,5	80
D	11	14	20	21
E	3,5	5	5	5
F	30	45	45	67
G	20	26	26	28
H	33	41	42,5	67
J	8,4	10,5	13	17
K	13,5	16,5	19	25
L	-	-	-	-
M	27	34	-	-
R	1,5 x 60°	1,5 x 60°	1,5 x 60°	1,5 x 60°
Weight/jaw kg	0,550	1,125	1,400	3,125

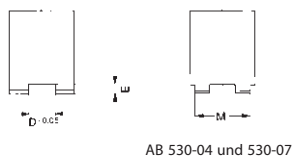

AB 530-04 und 530-07

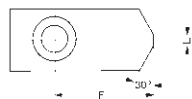

AB 530-02

Chucking capacities with reversible top jaw UB

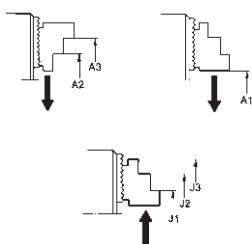

Chuck size		160	215	280	350
with reversible jaws	Type	530-04	530-07	530-09	530-12
	Jaw position				
External chucking	A1	5-115	5-136	11-185	50-248
	A2	58-175	81-220	123-295	159-354
	A3	92-208	132-272	190-363	242-438
Internal chucking	J1	52-159	61-186	70-238	108-301
	J2	85-193	109-238	133-305	189-385
	J3	129-240	167-298	202-378	274-472