

KFD-HS



APPLICATION

Premium power chucks with through-hole for maximum speeds with simultaneously low centrifugal force losses.

TYPE

Power chuck available with cylindrical center mount or short taper mount.
3-jaw version with serration (90°) or tongue and groove.
2-jaw version with serration (90°).

CUSTOMER BENEFITS

- ⊕ Low centrifugal force losses and high speeds thanks to special wedge hook system with annular piston
- ⊕ Larger than average through-hole for wide range of workpieces
- ⊕ Maximum precision thanks to rigid chuck construction
- ⊕ If necessary quick conversion to a different spindle nose by simply exchanging the centering adapter

TECHNICAL FEATURES

- Universal construction of the piston connection (piston does not project into the spindle bore area, even with the piston position moved back)
- Long jaw guide
- Clamping inserts can be used for bar machining (special version)

Included in the scope of delivery:

Chuck, chuck and jaw mounting screws, mounting wrench, slot nuts (without top jaws)

Gripping force/speed diagram (3-jaw chucks only)

The loss of gripping force was determined experimentally on a chuck with matched UB top jaws. It is largely independent of the initial gripping force at zero speed.

Upper curve:
min. centrifugal force of top jaw



Lower curve:
max. centrifugal force of top jaw



To obtain the specified gripping forces, the chuck must be in a perfect condition and lubricated with F 80 lubricant recommended by RÖHM. Measuring point near chuck face.

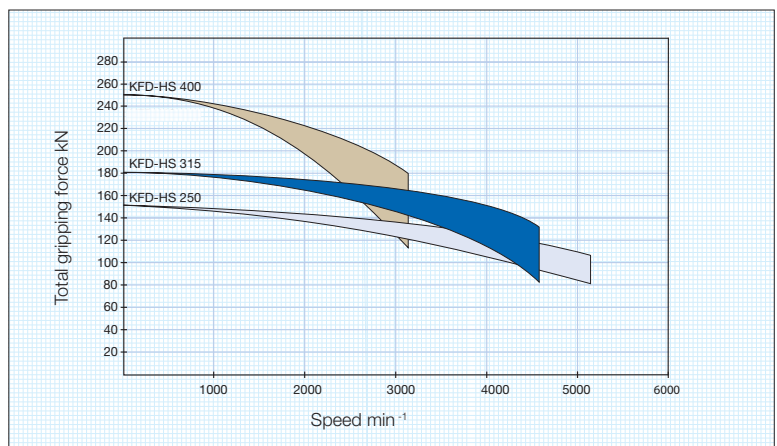
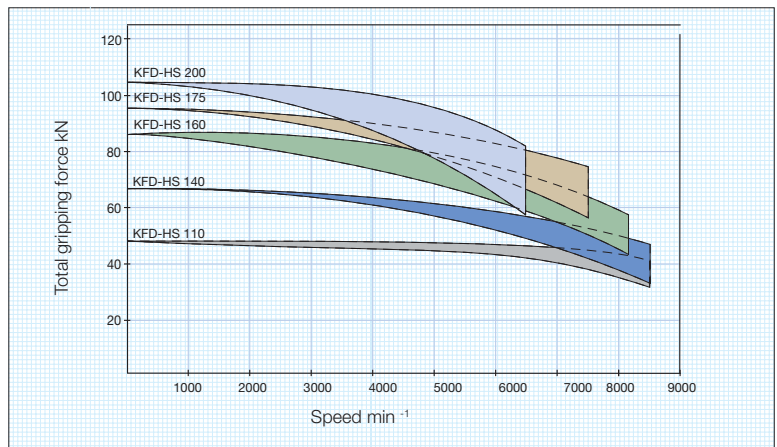

Power chuck with through-hole KFD-HS

KFD-HS 3-jaw, serration 90°

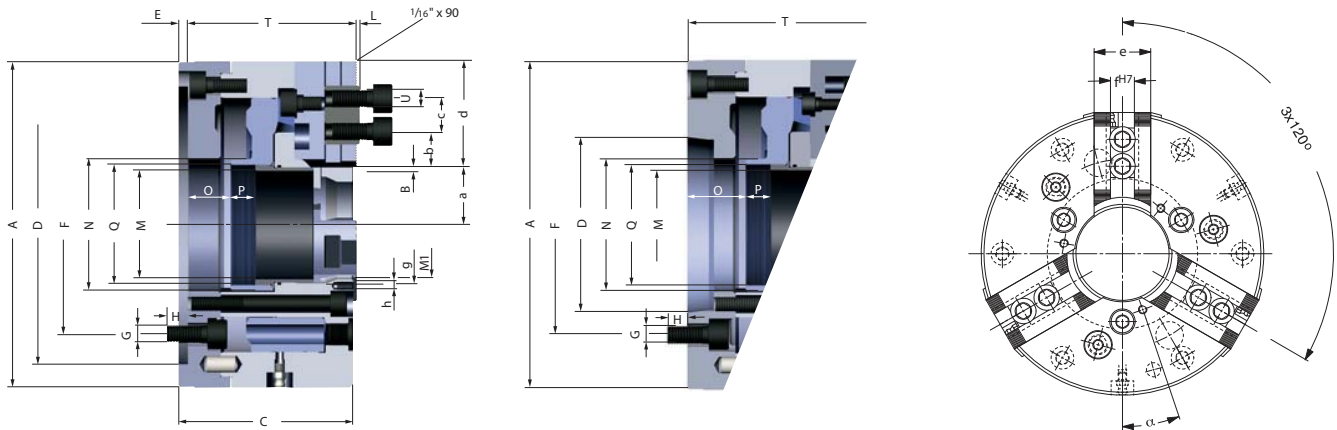

C 15

3-jaw power chuck KFD-HS, with tightening thread, serration 90°

Cylindrical center mount, connection dimensions in acc. with DIN 6353/short taper mount (KK) for ISO 702-1 (DIN 55026/55021)

Item no.	149406	149405	144258	142690	143692	142478	144259	143893	143888	142479
Size	110	110	140	140	160	160	175	175	200	200
number of jaws	3	3	3	3	3	3	3	3	3	3
A mm	110	110	140	140	160	160	175	175	200	200
Jaw travel B mm	3,2	3,2	3,2	3,2	4	4	4	4	5	5
C mm	78	86	88	92	102	108	102	108	107	112
Mount D	ZA 60	KK 4 ¹⁾	ZA 120	KK 5	ZA 140	KK 5	ZA 140	KK 5	ZA 170	KK 6
E mm	6	13	6	15	6	16	6	16	6	16
F mm	82,6	82,6	104,8	104,8	104,8	104,8	104,8	104,8	133,4	133,4
G	3xM10	3xM10	3xM10	3xM10	3xM10	3xM10	3xM10	3xM10	3xM12	3xM12
H mm	14	14	15	17	15	14	15	14	18	17
Wedge stroke K mm	12	12	12	12	15	15	15	15	18,5	18,5
L mm	2,5	2,5	2,5	2,5	2,5	2,5	2,5	2,5	2,5	2,5
M max. mm	26	26	37	37	46	46	56	56	66	66
M1H7 mm	32	32	37	37	46	46	56	56	66	66
N mm	38	38	48	48	58	58	68	68	80	80
O min.	-1	11	5	13	6	16	6	16	7,5	16,5
O max.	11	23	17	25	21	31	21	31	26	35
P mm	12	12	14	14	16	16	16	16	15	15
Q mm	M34x1,5	M34x1,5	M44x1,5	M44x1,5	M54x1,5	M54x1,5	M65x1,5	M65x1,5	M74x1,5	M74x1,5
T mm	80	84	84	90	98	106	98	106	103	110
U mm	M8	M8	M6	M6	M8	M8	M8	M8	M12	M12
a min.	10,8	10,8	16,8	16,8	24	24	29	29	35	35
a max.	14	14	20	20	28	28	33	33	40	40
b min.	3	3	0	0	0	0	0	0	8,5	8,5
b max.	23	23	26	26	22	22	24,5	24,5	32,5	32,5
c mm	15	15	2x12	2x12	2x15	2x15	2x15	2x15	19	19
d mm	41	41	50	50	52	52	54,5	54,5	60	60
e mm	24	24	25	25	32	32	32	32	40	40
fH7-0,025 mm	10	10	10	10	12	12	12	12	17	17
g mm	50	50	68	68	76	76	76	76	84	84
h		M5x8	M5x8	M5x8	M6x10	M6x10	M6x10	M6x10	M6x10	M6x10
α	0°	0°	22° 30'	22° 30'	20°	20°	20°	20°	20°	20°
Max. swing top jaws mm	113	113	180	180	195	195	210	210	250	250
Maximum draw bar pull kN	18	18	25	25	35	35	40	40	48	48
Max. total clamping force kN	48	48	70	70	86	86	95	95	110	110
Max. admissible speed min ⁻¹	8500	8500	8000	8000	8000	8000	7000	7000	6500	6500
Moment of inertia J kgm ²	0,007	0,007	0,022	0,022	0,0415	0,0415	0,057	0,057	0,1	0,1
Weight without jaws approx. kg	5	5	9	9	12	12	15	15	20	20
Actuating cylinders (recommended)	OVS-85 / SZS-37/70	OVS-85 / SZS-37/70	OVS-105 / SZS-37/70	OVS-105 / SZS-37/70	OVS-105 / SZS-46/103	OVS-105 / SZS-46/103	OVS-105 / SZS-52/130	OVS-105 / SZS-52/130	OVS-130 / SZS-67/150	OVS-130 / SZS-67/150

* ISO 702-1 (DIN 55026) only (DIN 55021 on request)

KFD-HS 3-jaw, serration 90°

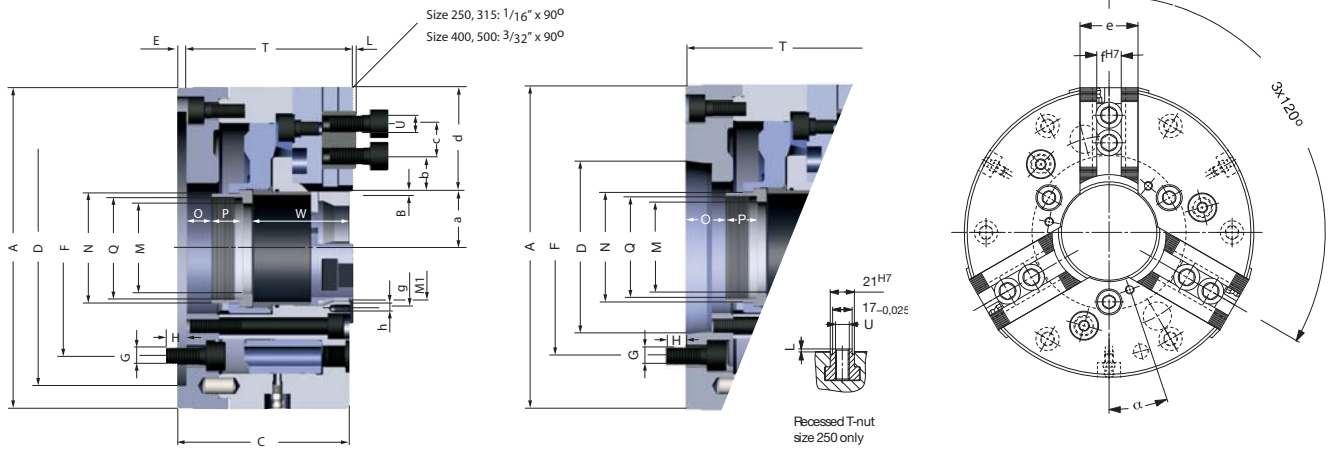

C 15

3-jaw power chuck KFD-HS, with tightening thread, serration 90°

Cylindrical center mount, connection dimensions in acc. with DIN 6353/short taper mount (KK) for ISO 702-1 (DIN 55026/55021)

Item no.	161725	144260	143726	142691	144261	143748	144262	143749	144263	143750	143751
Size	250	250	250	250	315	315	315	315	400	400	400
number of jaws	3	3	3	3	3	3	3	3	3	3	3
A mm	250	250	250	250	315	315	315	315	400	400	400
Jaw travel B mm	6,2	6,2	6,2	6,2	6,2	6,2	6,2	6,2	7,5	7,5	7,5
C mm	128	128	130	130	128	130	139	143	156	156	156
Mount D	ZA 170	ZA 220	KK 6	KK 8	ZA 220	KK 8	ZA 300	KK 11	ZA 380	KK 11	KK 15
E mm	6	6	15	19	6	19	6	21	6	18	21
F mm	133,4	171,4	133,4	171,4	171,4	171,4	235	235	330,2	235	330,2
G	3xM12	3xM16	3xM12	3xM16	3xM16	3xM16	3xM20	3xM20	3xM24	3xM20	3xM24
H mm	16	24	18	24	24	24	30	30	30	30	30
Wedge stroke K mm	23	23	23	23	23	23	23	23	28	28	28
L mm	2,5	2,5	2,5	2,5	2,5	2,5	2,5	2,5	3,5	3,5	3,5
M max. mm	66	86	66	86	86	86	108	108	165	126	165
M1H7 mm	94	94	94	94	94	94	115	115	172	172	172
N mm	110	99	80	99	99	99	126	126	180	142	180
O min.	0	-6	2	2	-6	2	-9	1	-12	0	-6
O max.	23	17	25	25	17	25	14	24	16	28	22
P mm	19	25	25	25	25	25	25	25	35	35	35
Q mm	M74x1,5	M94x1,5	M74x1,5	M94x1,5	M94x1,5	M94x1,5	M120x1,5	M120x1,5	M172x3	M132x1,5	M172x3
T mm	124	124	132	132	124	132	135	145	153	159	159
U mm	M12	M12	M12	M12	M16	M16	M16	M16	M20	M20	M20
W mm	74	74	74	74	74	74	85	85	88	88	88
a min.	43,8	43,8	43,8	43,8	43,8	43,8	54,8	54,8	80,5	80,5	80,5
a max.	50	50	50	50	50	50	61	61	88	88	88
b min.	6	6	6	6	10,5	10,5	10,5	10,5	14,5	14,5	14,5
b max.	47,5	47,5	47,5	47,5	72	72	61	61	66,5	66,5	66,5
c mm	19	19	19	19	25	25	25	25	31	31	31
d mm	75	75	75	75	107,5	107,5	96,5	96,5	112	112	112
e mm	50	50	50	50	50	50	50	50	60	60	60
fH7-0,025 mm	17	17	17	17	21	21	21	21	25,5	25,5	25,5
g mm	108	108	108	108	108	108	136	136	190	190	190
h	M6x10	M6x10	M6x10	M6x10	M6x10	M6x10	M8x12	M8x12	M8x12	M8x12	M8x12
α	15°	0°	15°	0°	0°	0°	0°	0°	15°	15°	15°
Max. swing top jaws mm	305	305	305	305	380	380	380	380	520	520	520
Maximum draw bar pull kN	65	65	65	65	80	80	80	80	110	110	110
Max. total clamping force kN	150	150	150	150	180	180	180	180	250	250	250
Max. admissible speed min ⁻¹	5000	5000	5000	5000	4200	4200	4200	4200	3150	3150	3150
Moment of inertia J kgm ²	0,35	0,35	0,35	0,35	0,74	0,74	0,74	0,74	2,4	2,4	2,4
Weight without jaws approx. kg	40	40	40	40	56	56	56	56	120	120	120
Actuating cylinders (recommended)	OVS-150 / SZS-67/150	OVS-150 / SZS-86/200	OVS-150 / SZS-67/150	OVS-200 / SZS-86/200	OVS-200 / SZS-86/200	OVS-200 / SZS-86/200	OVS-200 / SZS-110/250	OVS-200 / SZS-110/250	OVS 200 / -	OVS-200 / SZS-127/325	OVS-200 / -

* ISO 702-1 (DIN 55026) only (DIN 55021 on request)

Power chuck with through-hole KFD-HS

KFD-HS 3-jaw, tongue and groove

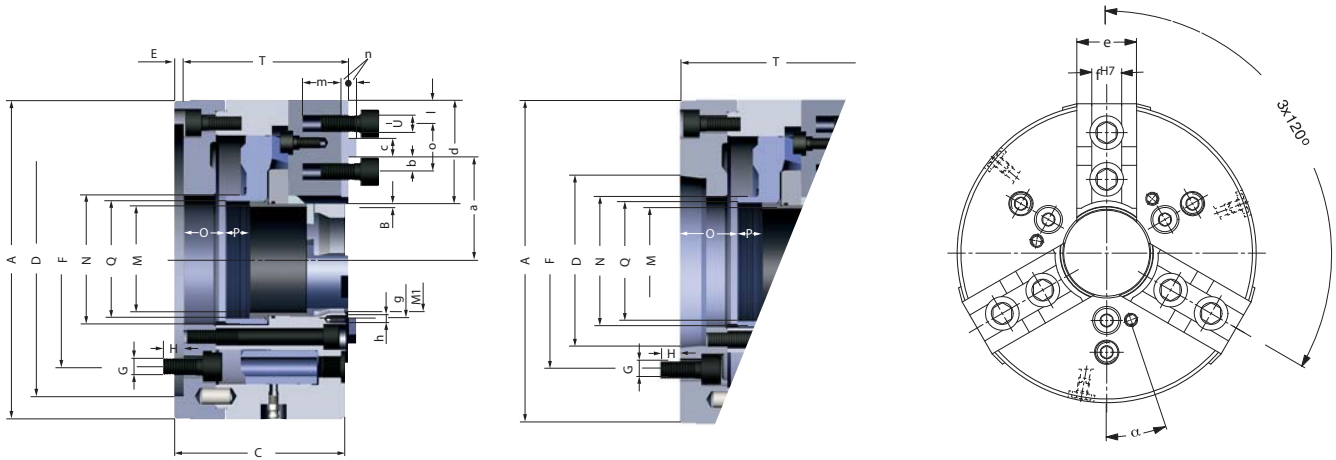

C15

3-jaw power chuck KFD-HS, with tightening thread, with tongue and groove

Cylindrical center mount, connection dimensions in acc. with DIN 6353/short taper mount (KK) for ISO 702-1 (DIN 55026/55021)

Item no.	149846	149543	151532 ▲	156580 ▲	153182	157768	154239	155099
Size	110	110	140	140	160	160	200	200
number of jaws	3	3	3	3	3	3	3	3
A mm	110	110	140	140	160	160	200	200
Jaw travel B mm	3,2	3,2	3,2	3,2	4	4	5	5
C mm	80	86	88	92	102	108	107	112
Mount D	ZA 60	KK 4 ¹⁾	ZA 120	KK 5	ZA 140	KK 5	ZA 170	KK 6
E mm	6	13	6	16	6	15	6	16
F mm	82,6	82,6	104,8	104,8	104,8	104,8	133,4	133,4
G	3xM10	3xM10	3xM10	3xM10	3xM10	3xM10	3xM12	3xM12
H mm	14	14	15	17	14	15	18	17
Wedge stroke K mm	12	12	12	12	15	15	18,5	18,5
M max. mm	26	26	37	37	46	46	66	66
M1H7 mm	32	32	37	37	46	46	66	66
N mm	38	38	48	48	58	58	80	80
O min.	-1	11	5	13	6	16	7,5	16,5
O max.	11	23	17	25	21	31	26	35
P mm	12	12	14	14	16	16	15	15
Q mm	M34x1,5	M34x1,5	M44x1,5	M44x1,5	M54x1,5	M54x1,5	M74x1,5	M74x1,5
T mm	78	80	84	90	98	106	103	110
U mm	M8	M8	M12	M12	M12	M12	M12	M12
a min.	31,8	31,8	45,3	45,3	43	43	59	59
a max.	35	35	48,5	48,5	47	47	64	64
c mm	10	10	13	13	10	10	12	12
d mm	30	30	50	50	56	56	65	65
e mm	24	24	25	25	32	32	40	40
fH7-0,025 mm	10	10	8	8	16	16	16	16
g mm	50	50	68	68	76	76	84	84
h	M5x8	M5x8	M5x8	M5x8	M6x10	M6x10	M6x10	M6x10
l mm	6,5	6,5	29	29	15,5	15,5	15	15
m mm	11	11	19	19	18	18	20	20
n mm	3	3	3	3	5	5	5	5
α	0°	0°	22° 30'	22° 30'	20°	20°	20°	20°
Max. swing top jaws mm	113	113	180	180	170	170	210	210
Maximum draw bar pull kN	18	18	25	25	35	35	48	48
Max. total clamping force kN	48	48	70	70	86	86	110	110
Max. admissible speed min ⁻¹	8500	8500	8000	8000	8000	8000	6500	6500
Moment of inertia J kgm ²	0,007	0,007	0,022	0,022	0,0415	0,0415	0,1	0,1
Weight without jaws approx. kg	5	5	9	9	12	12	20	20
Actuating cylinders (recommended)	OVS-85 / SZS-37/70	OVS-85 / SZS-37/70	OVS-105 / SZS-37/70	OVS-105 / SZS-37/70	OVS-105 / SZS-46/103	OVS-105 / SZS-46/103	OVS-130 / SZS-67/150	OVS-130 / SZS-67/150

* ISO 702-1 (DIN 55026) only (DIN 55021 on request)

KFD-HS 2-jaw, serration 90°

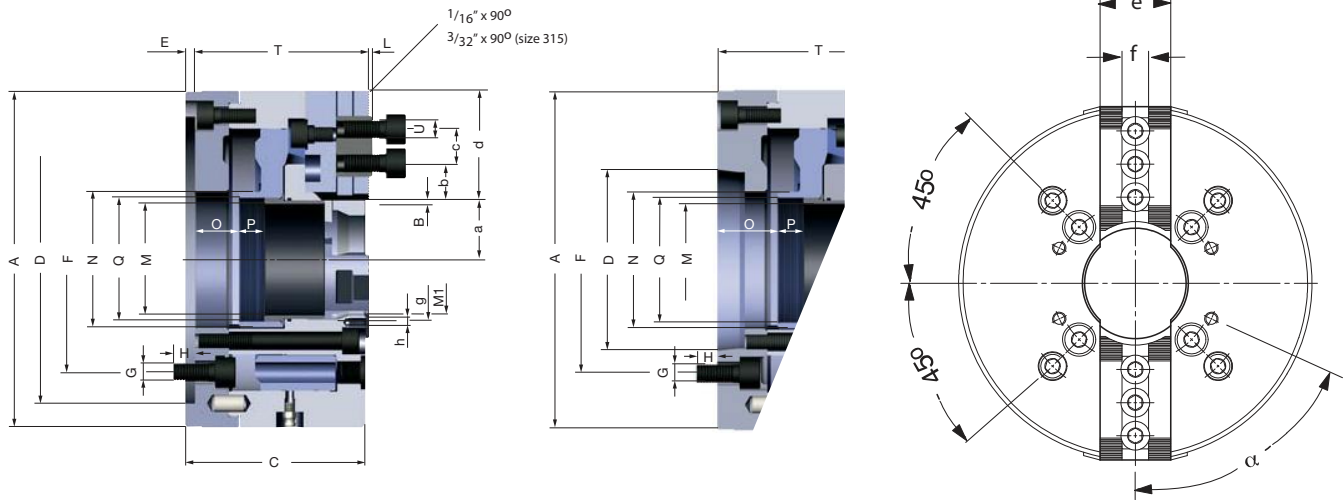

C15

2-jaw power chuck KFD-HS, with tightening thread, serration 90°

Cylindrical center mount, connection dimensions in acc. with DIN 6353/short taper mount (KK) for ISO 702-1 (DIN 55026/55021)

Item no.	147281	147282	147285	147286	148036	148023	148031	162995
Size	160	160	200	200	250	250	250	315
number of jaws	2	2	2	2	2	2	2	2
A mm	160	160	200	200	250	250	250	315
Jaw travel B mm	4	4	5	5	6,2	6,2	6,2	6,25
C mm	102	108	107	112	128	132	132	130
Mount D	ZA 140	KK 5	ZA 170	KK 6	ZA 220	KK 6	KK 8	ZA 300
E mm	6	15	6	16	6	15	19	6
F mm	104,8	104,8	133,4	133,4	171,4	133,4	171,4	235
G	4xM10	4xM10	4xM12	4xM12	4xM16	4xM12	4xM16	4xM20
H mm	15	14	18	17	24	18	24	30
Wedge stroke K mm	15	15	18,5	18,5	23	23	23	23
L mm	2,5	2,5	2,5	2,5	2,5	2,5	2,5	3,5
M max. mm	46	46	66	66	86	66	86	108
M1H7 mm	46	46	66	66	94	94	94	115
N mm	58	58	80	80	99	80	99	126
O min.	6	16	7,5	16,5	-6	2	2	-9
O max.	21	31	26	35	17	25	25	14
P mm	16	16	15	15	25	25	25	25
Q mm	M54x1,5	M54x1,5	M74x1,5	M74x1,5	M94x1,5	M74x1,5	M94x1,5	M120x1,5
T mm	98	106	103	110	124	130	130	135
U mm	M8	M8	M 12	M12	M12	M12	M12	M16
W mm	-	-	-	-	-	74	74	85
a min.	24	24	35	35	43,8	43,8	43,8	54,8
a max.	28	28	40	40	50	50	50	61
b min.	0	0	8,5	8,5	6	6	6	10,5
b max.	22	22	32,5	32,5	47,5	47,5	47,5	61
c mm	2x15	2x15	19	19	19	19	19	25
d mm	52	52	60	60	75	75	75	96,5
e mm	32	32	40	40	50	50	50	50
fH7-0,025 mm	12	12	17	17	17	17	17	21
g mm	76	76	84	84	108	108	108	136
h	M6x10	M6x10	M6x10	M6x10	M6x10	M6x10	M6x10	M8x12
α	40°	40°	60°	60°	60°	60°	60°	60°
Max. swing top jaws mm	170	170	250	250	305	305	305	380
Maximum draw bar pull kN	20	20	30	30	42	42	42	55
Max. total clamping force kN	45	45	66	66	94	94	94	120
Max. admissible speed min-1	8000	8000	6500	6500	5000	5000	5000	4200
Moment of inertia J kgm ²	0,0415	0,0415	0,1	0,1	0,35	0,35	0,35	0,62
Weight without jaws approx. kg	12	12	20	20	40	40	40	60
Actuating cylinders (recommended)	OVS-105 / SZS-46/103	OVS-105 / SZS-46/103	OVS-130 / SZS-67/150	OVS-130 / SZS-67/150	OVS-150 / SZS-67/150	OVS-150 / SZS-67/150	OVS-150 / SZS-86/200	OVS-200 / SZS-110/250

Other sizes on request

Power chuck with through-hole KFD-HS

Jaws KFD-HS

C 21

Reversible top jaws, hardened serration 90° - material: 16 MnCr 5



Chuck Size	2-jaw set	3-jaw set	Jaw length mm	Jaw height mm	Jaw width mm	Serration
110	-	149352	45	32	26	1/16"x 90°
140	046545	046544	56	37,5	26	1/16"x 90°
160/175	045796	046404	56	37,5	26	1/16"x 90°
160/175	-	351320	51,5	26	26	1/16"x 90°
200/250	118521	118522	75	49	36	1/16"x 90°
315	046435	046414	103,5	58	50	1/16"x 90°
400	046447	037531	135	65	68	3/32"x 90°

¹⁾ Additionally or later applied, hardened jaws must be ground out in the chuck!

C 21

Soft top jaws, can be hardened serration 90° - material: 16 MnCr 5



Chuck Size	2-jaw set	3-jaw set	Jaw length mm	Jaw height mm	Jaw width mm	Serration
110	-	149353	45	38	26,5	1/16"x 90°
140	045794	046402	53	30	22,5	1/16"x 90°
160/175	045795	046403	55	38	26,5	1/16"x 90°
200	133147	133152	66,7	53	36,5	1/16"x 90°
250	133148	133153	75	53	36,5	1/16"x 90°
315	133149	133154	95	54,5	45	1/16"x 90°
400	133151	133156	130	80	50	3/32"x 90°

C 21

Soft top jaws, 3-jaw set, can be hardened tongue and groove 120° bevelled, material: 16 MnCr 5



Chuck Size	3-jaw set	Jaw length mm	Jaw height mm	Jaw width mm
110	144082	53	30	22,5
140	123355	58	38	26,5
160	123358	72,7	53	36,5
200	123430	90,3	53	36,5

C 21

Claw-type jaws, 1 piece, hardened serration 90° - width of the groove 10



Item no.	Chuck Size	Jaw length mm	Jaw height mm	Claw length mm	Serration
149920	110	42	27	37,1	1/16"x 90°
149921	110	42	27	23,4	1/16"x 90°
149922	110	47	27	17,7	1/16"x 90°

C 21

Claw-type jaws, 1 piece, hardened serration 90° - width of the groove 10



Item no.	Chuck Size	Jaw length mm	Jaw height mm	Claw length mm	Serration
147259	140	50	27	41	1/16"x 90°
147261	140	44	27	22	1/16"x 90°

Jaws KFD-HS

C 21
Claw-type jaws, 1 piece, hardened serration 90° - width of the groove 12



Item no.	Chuck Size	Jaw length mm	Jaw height mm	Claw length mm	Serration
144320	160/175	66	38	52	1/16"x 90°
144321	160/175	56	38	34	1/16"x 90°
144322	160/175	66	38	25	1/16"x 90°

C 21
Claw-type jaws, 1 piece, hardened serration 90° - width of the groove 17



Item no.	Chuck Size	Jaw length mm	Jaw height mm	Claw length mm	Serration
137031	200/250	67	45	53	1/16"x 90°
137032	200/250	65	45	46	1/16"x 90°
137033	200/250	55	45	39	1/16"x 90°
137034	200/250	50	45	31	1/16"x 90°
137035	200/250	55	45	27	1/16"x 90°
137036	200/250	65	45	19	1/16"x 90°
137037	200/250	65	45	26	1/16"x 90°
137038	200/250	55	45	24	1/16"x 90°
137039	200/250	55	45	40	1/16"x 90°

C 21
Claw-type jaws, 1 piece, hardened serration 90° - width of the groove 21



Item no.	Chuck Size	Jaw length mm	Jaw height mm	Claw length mm	Serration
137041	250/315	95	50	80	1/16"x 90°
137042	250/315	75	50	60	1/16"x 90°
137043	250/315	60	50	43	1/16"x 90°
137044	250/315	70	50	37	1/16"x 90°
137045	250/315	95	50	25	1/16"x 90°
137046	250/315	80	50	30	1/16"x 90°

C 21
Claw-type jaws, 1 piece, hardened serration 90° - width of the groove 25,5



Item no.	Chuck Size	Jaw length mm	Jaw height mm	Claw length mm	Serration
137051	400	130	65	113	3/32"x 90°
137052	400	90	65	67	3/32"x 90°
137053	400	100	65	45	3/32"x 90°
137054	400	130	65	33	3/32"x 90°

Accessories KFD-HS

C 15
Extended T-nuts
With screw

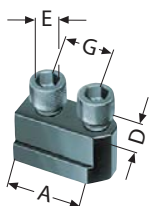

Item no.	Chuck Size	Con- tents of delivery	A mm	D mm	E	G mm
1305164	110	piece	30	10	M8x20	15
1305165	140	piece	34	10	M6x18	2x12
1305166	160/175	piece	42	12	M8x20	2x15
1305167	200	piece	36	17	M12x25	19
1305168	250	piece	36	17	M12x25	19
1305169	315	piece	46	21	M16x30	25
1305170	400	piece	59	25,5	M20x40	31

Configure your individual clamping jaws online! www.web2product.biz

Accessories KFD-HS

C 15

Intermediate adaptor plates with cylindrical centre mount DIN 6353 for 3-jaw chucks

Mounting from front to ISO 702-1 (DIN 55026/55021) and ASA B 5.9 A1/A2 with metric mounting bolts

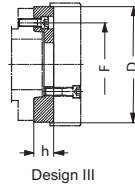
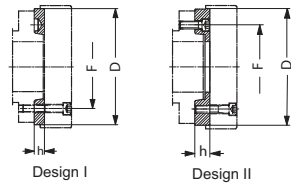

Item no.	Spindle nose size	Size	Design	h mm	F mm	D mm
145125 ¹⁾	4	160	II	18	82,6	140
145153	5	175	I	15	104,8	140
145127	5	200	II	21	104,8	170
145129	6	160	III	35	133,4	140
145297	6	175	III	35	133,4	140
145155	6	200	I	16	133,4	170
145131	6	250	II	27	133,4	220
145135	8	200	III	39	171,4	170
145157	8	250	I	18	171,4	220
145139	8	315	II	38	171,4	300
145143	11	250	III	48	235	220
145159	11	315	I	19	235	300
145147	11	400	II	40	235	380
145161	15	400/500/630	I	21	330,2	380

¹⁾ DIN 55021 on request

All fastening parts are included

Intermediate adaptor plate for 2-jaw version on request

Jaw dimensions KFD-HS

Reversible top jaws UB,
hardened, serration 90°,
material 16MnCr5

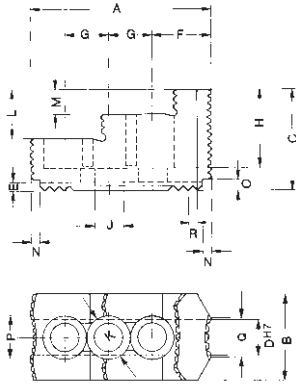

Chuck size	110	140	160/175	160	200/250	315	400/500
Type	543-21	537-02	538-02	543 1)	538-04	538-05	538-07
Item no. 2-jaw	-	046545	045796	-	118521	046435	046447
Item no. 3-jaw	149352	046544	046404	351320	118522	046414	037531
A	45	56	56	51,5	75	103,5	135
B	26	26	26	26	36	50	68
C	32	37,5	37,5	26	49	58	65
D ^{H7}	10	10	12	12	17	21	25,5
E	3,5	3,5	3,5	3,5	5	5	5
F	15	10	14	23	21,5	33,5	48
G	15	12 3)	15	15 4)	19	25	31
H	23	29	29	17	37,5	45	48
J	8,4	6,4	8,4	9	13	17	21
K	13,5	10,4	13,5	14	19	25	31
L	14	20	20	-	24	28	-
M	7	10	10	8	12	14	26
N	4	4	4	3	6	6	6,5
O	4	4	4	4	7,5	6,5	5,5
P	8	5	5	20	18	24,5	34
Q	5	5	5	3	7	22,5	40
R	1/16"x90°	1/16"x90°	1/16"x90°	1/16"x90°	1/16"x90°	1/16"x90°	3/32"x90°
Weight/jaw kg	0,155	0,130	0,170	0,150	0,460	1,130	2,000

1) one step only, for 8000 min-1
2) one step only, extended

3) 4 mounting holes
4) 2 mounting holes

Soft top jaws AB,
serration 90°,
material 16MnCr5

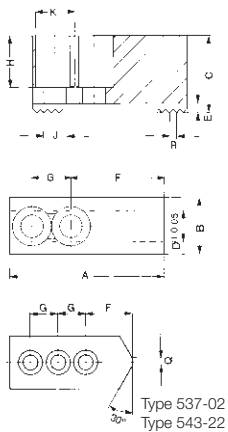

Chuck size	110	140	160/175	200	250	315	400/500
Type	543-22	537-02	538-02	538-03	538-04	538-05	538-07
Item no. 2-jaw	-	045794	045795	133147	133148	133149	133151
Item no. 3-jaw	149353	046402	046403	133152	133153	133154	133156
A	45	53	55	66,7	75	95	130
B	26,5	22,5	26,5	36,5	36,5	45	50
C	38	30	38	53	53	54,5	80
D	10	10	12	17	17	21	25,5
E	3,5	3,5	3,5	5	5	5	5
F	15	20	31	36	44	55	79
G	15	12 1)	15	19	19	25	31
H	23	20	28	43	43	42,5	60
J	8,4	6,4	8,4	13	13	17	21
K	13,5	10,4	13,5	19	19	25	31
Q	5	3	-	-	-	-	-
R	1/16"x90°	1/16"x90°	1/16"x90°	1/16"x90°	1/16"x90°	1/16"x90°	3/32"x90°
Weight/jaw kg	0,210	0,223	0,320	0,700	0,880	1,400	3,100

1) 3 mounting holes

Soft top jaws AB,
with tongue and groove,
material 16MnCr5

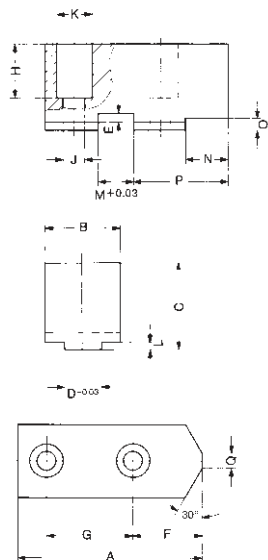

Chuck size	110	140	160	200
Type	549-10	538-22	538-13	538-14
Item no. 3-jaw	144082	123355	123358	123430
A	53	58	72,7	90,3
B	22,5	26,5	36,5	36,5
C	30	38	53	53
D _{-0,03}	10	8	16	16
E	3,5	3,5	5,5	5,5
F	26,5	31,5	32,2	45,3
G	17	-	25	30
H	20	25	38	38
J	9	13	13	13
K	15	19	19	19
L	2,5	2,5	4,5	4,5
M+0,03	10	13	10	12
N	20	23	24,7	35,3
O	4	3	5	5
P	30	39,5	39,7	54,3
Q	3	3	3	6
Weight/jaw kg	0,21	0,46	0,720	1,0

Jaw dimensions
KFD-HS

Chucking capacities KFD-HS

Chucking capacities with reversible top jaws UB, for 3-jaw chucks

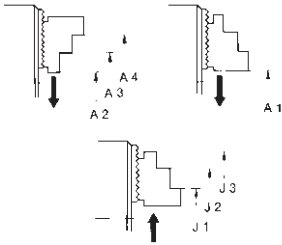

Chuck size		110	140	160	160*	175	200	200**	250	315	400
with reversible jaws	Type	543-21	527-02	538-02	543	538-02	538-04	543-09	538-04	538-05	538-07
	Jaw position										
External chucking	A1	6-46	5-68	6-67	4-52	6-82	12-98	4-70	22-144	25-169	30-203
	A2	-	-	-	21-73	-	26-112	-	40-156	45-196	47-250
	A3	41-76	52-115	53-118	-	54-133	82-165	-	94-210	127-280	-
	A4	68-106	87-150	88-165	94-146	90-180	132-218	112-170	146-262	209-360	245-453
Internal chucking	J1	42-80	35-100	36-99	32-84	36-114	61-144	60-126	76-192	76-216	96-280
	J2	70-108	70-135	71-134	-	71-149	110-198	-	128-244	150-348	-
	J3	96-135	117-182	118-181	102-157	118-196	162-248	-	182-298	230-380	277-478

* one step only

** one step only, extended