

# Sauter Revolver VDI 25 / DIN 5480

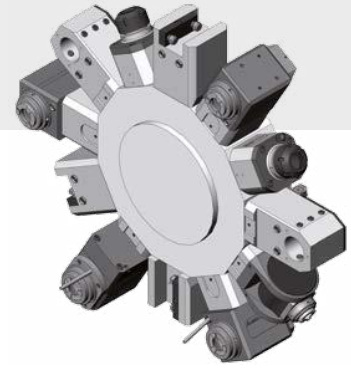

Gildemeister Sprint 32  
 Gildemeister Sprint 42  
 Gildemeister Twin 32  
 Gildemeister Twin 42 (Rahmengröße 1 | frame size 1)  
 Gildemeister Twin 65 (Rahmengröße 1 | frame size 1)  
 Sauter Revolver VDI 25

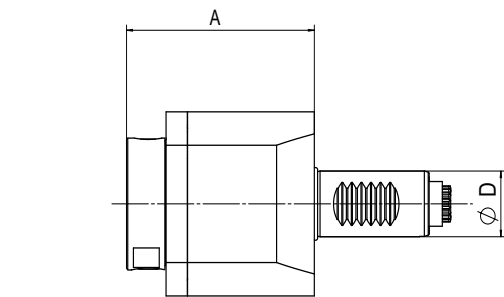

1

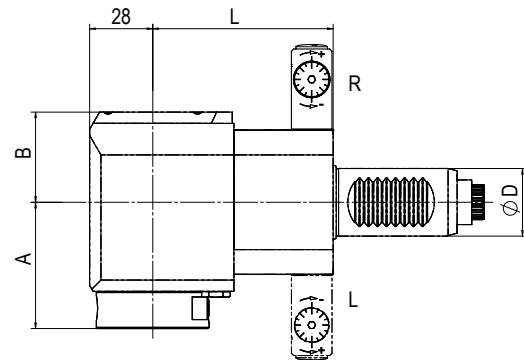

2

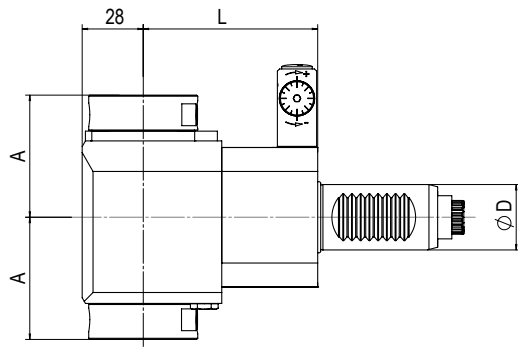

3

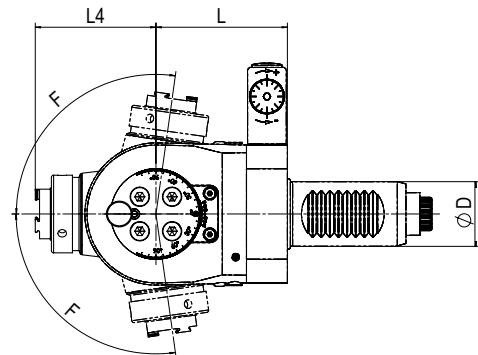

4

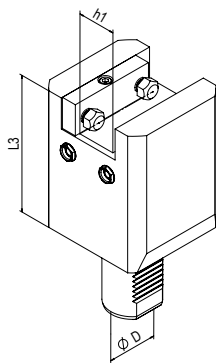

5

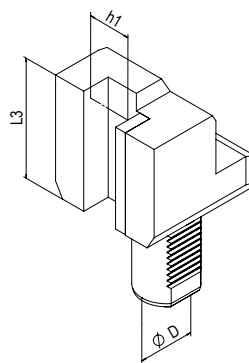

6

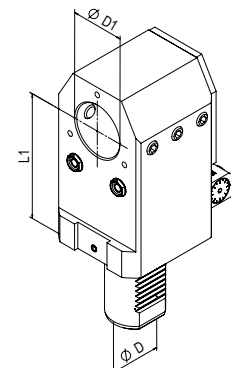

7

# Sauter Revolver VDI 25 / DIN 5480



## Angetriebene Werkzeuge | Live Tools

### BENZ Solidfix® Modulares Schnellwechselsystem | Modular Quick Change System

Bestell-Nr. Order No.	Ausführung Tool style	Bild Figure	Aufnahme Tool holder	n [min <sup>-1</sup> ]	Übersetzung Gear ratio	T [Nm]	EK EC	IK IC	pmax [bar]	Maße   Dimensions				
										D	A	B	L	L <sub>4</sub>
325DA00500S3	axial	1	BENZ Solidfix® S3	8.000	1:1	25	✓	-	-	25	58	-	-	-
325EA00531S3	axial	1		8.000	1:1	25	✓	✓	50	25	79	-	-	-
325FAX00539S3R-75	radial	2		8.000	1:1	30	✓	-	-	25	56	40	75	-
325FAX00539S3L-75	radial	2		8.000	1:1	30	✓	-	-	25	56	40	75	-
325GAX00539S3R-75	radial	2		8.000	1:1	30	✓	✓	100	25	56	58	75	-
325GAX00539S3L-75	radial	2		8.000	1:1	30	✓	✓	100	25	56	58	75	-
325FAX00539S32-75	radial Doppelspindel Double spindle	3		8.000	1:1	30	✓	-	-	25	56	-	75	-

Maß A: bis Plananlage, ohne Adapter | Dimension A: up to plane surface, without adapter

## Spannzange | Collet Chuck

Bestell-Nr. Order No.	Ausführung Tool style	Bild Figure	Aufnahme Tool holder	n [min <sup>-1</sup> ]	Übersetzung Gear ratio	T [Nm]	EK EC	IK IC	pmax [bar]	Maße   Dimensions				
										D	A*	B	L	L <sub>4</sub>
325DA00500E4A	axial	1	ER20	8.000	1:1	25	✓	-	-	25	51,5	-	-	-
325EA00531E4A	axial	1	ER20	8.000	1:1	25	✓	✓	50	25	77,5	-	-	-
325FAX00539E4AR-75	radial	2	ER20	8.000	1:1	30	✓	-	-	25	51	40	75	-
325FAX00539E4AL-75	radial	2	ER20	8.000	1:1	30	✓	-	-	25	51	40	75	-
325GAX00539E4AR-75	radial	2	ER20	8.000	1:1	30	✓	✓	100	25	56	58	75	-
325GAX00539E4AL-75	radial	2	ER20	8.000	1:1	30	✓	✓	100	25	51	58	75	-
325FAX00539E4A2-75	radial Doppelspindel Double spindle	3	ER20	8.000	1:1	30	✓	-	-	25	51	-	75	-
325FDX00539E3A	schwenkbar swiveling	4	ER16	8.000	1:0,88	12	✓	-	-	25	-	-	61	51,6
325GDX00539E3A	F= ±98°	4	ER16	8.000	1:0,88	12	✓	✓	50	25	-	-	61	56

EK: externe Kühlung, IK: interne Kühlung  
R: rechte Ausführung, L: linke Ausführung  
Maß A\*: max. Länge inkl. Spannmutter  
Zubehör (ab S. 103) ist nicht im Lieferumfang enthalten.  
Technische Änderungen vorbehalten.

EC: external coolant, IC: internal coolant  
R: right hand design, L: left hand design  
Dimension A\*: max. length incl. clamping nut  
Accessories (from p. 103) are not included in delivery.  
We reserve the right to modify technical contents.

Sauter  
Revolver  
VDI 25

## Statische Halter | Static tool holder

Bestell-Nr. Order No.	Ausführung Tool style	Bild Figure	Maße   Dimensions			
			D <sub>1</sub>	h <sub>1</sub>	L <sub>1</sub>	L <sub>3</sub>
325.5592080	Viereck-Queraufnahme   Square locking drive radial Haupt-, Gegenspindel, Überkopf   Main-, opposed spindle, overhead	5	-	20x20	-	80
325.5611655	Viereck-Längsaufnahme rechts   Turning Tool holder axial right	6	-	16x16	-	55
325.5621655	Viereck-Längsaufnahme links   Turning Tool holder axial left	-	-	16x16	-	55
325A005578001	Bohrstangenhalter   Boring bar holder Haupt-, Gegenspindel mit IK   Main-, opposed spindle with IC	7	Ø25	-	80	-

Weitere Ausführungen ab S. 92 | Additional models from p. 92

# Sauter Revolver VDI 30 / DIN 5480

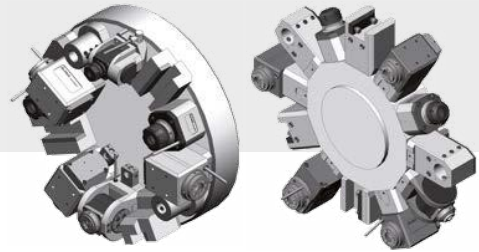

Colchester Tornado TT 6  
Doosan Z 290 M / SM  
Emco Turn 365  
Emco Turn 365-42  
Emco Hyperturn 645 MC Plus  
Emco Hyperturn 665 MC Plus  
Gildemeister CTX 210  
Gildemeister CTX 310  
Gildemeister CTX 320 linear

Gildemeister CTX 400 E  
Gildemeister CTX 400 Twin  
Gildemeister CTX 410  
Gildemeister CTX 420  
Gildemeister CTX alpha 300  
Gildemeister CTX alpha 500  
Gildemeister MF Twin 42  
Gildemeister MF Twin 65  
Gildemeister Sprint 32 linear

Gildemeister Sprint 65 linear  
Gildemeister Twin 42 (Rahmengröße 2)  
Gildemeister Twin 65 (Rahmengröße 2)  
Gildemeister Twin 102 mit B-Achse  
Graziano CTX 310  
Graziano CTX 320  
HURCO TMM 8  
Weiler DZ 67

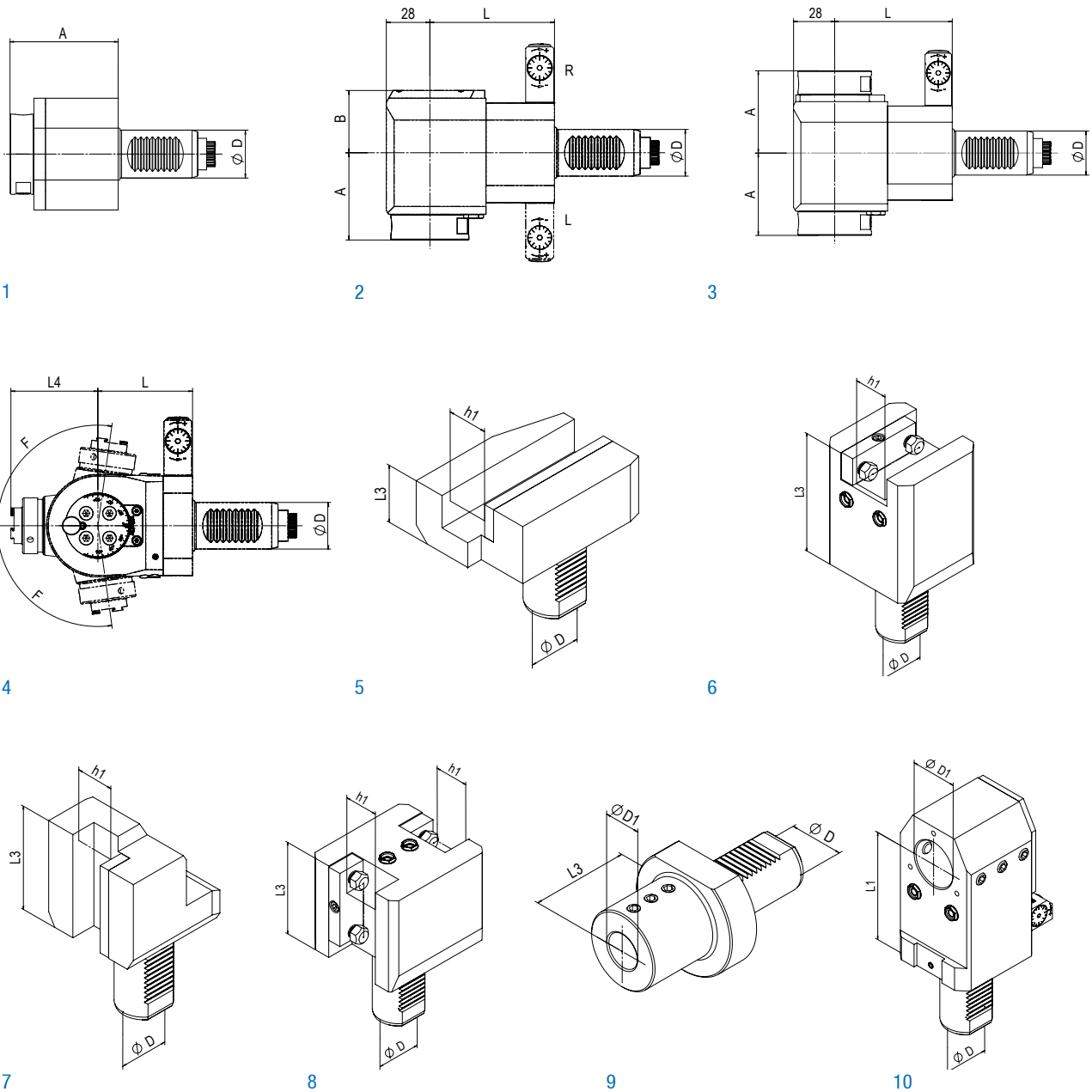

# Sauter Revolver VDI 30 / DIN 5480



## Angetriebene Werkzeuge | Live Tools

### BENZ Solidfix® Modulares Schnellwechselsystem | Modular Quick Change System

Bestell-Nr. Order No.	Ausführung Tool style	Bild Figure	Aufnahme Tool holder	n [min <sup>-1</sup> ]	Übersetzung Gear ratio	T [Nm]	EK EC	IK IC	pmax [bar]	Maße   Dimensions			
										D	A	B	L
113DA01200S3	axial	1		8.000	1:1	25	✓	-	-	30	58	-	-
113EA01231S3	axial	1		8.000	1:1	25	✓	✓	50	30	79	-	-
113FAX01239S3R	radial	2		8.000	1:1	30	✓	-	-	30	56	40	55
113FAX01239S3L	radial	2		8.000	1:1	30	✓	-	-	30	56	40	55
113GAX01239S3R	radial	2		8.000	1:1	30	✓	✓	100	30	56	58	55
113GAX01239S3L	radial	2		8.000	1:1	30	✓	✓	100	30	56	58	55
113FAX01239S3R-80	radial	2		8.000	1:1	30	✓	-	-	30	56	40	80
113FAX01239S3L-80	radial	2		8.000	1:1	30	✓	-	-	30	56	40	80
113GAX01239S3R-80	radial	2		8.000	1:1	30	✓	✓	100	30	56	58	80
113GAX01239S3L-80	radial	2		8.000	1:1	30	✓	✓	100	30	56	58	80
113FAX01239S3D-80	Doppel- verzahnung	2	BENZ Solidfix® S3	8.000	1:1	30	✓	-	-	30	56	40	80
113GAX01239S3D-80	Double spline	2		8.000	1:1	30	✓	✓	100	30	56	58	80
113FAX01239S32-80	Doppelspindler Double spindle	3		8.000	1:1	30	✓	-	-	30	56	-	80
113FAX01239S3R-100	radial	2		8.000	1:1	30	✓	-	-	30	56	40	100
113FAX01239S3L-100	radial	2		8.000	1:1	30	✓	-	-	30	56	40	100
113GAX01239S3R-100	radial	2		8.000	1:1	30	✓	✓	100	30	56	58	100
113GAX01239S3L-100	radial	2		8.000	1:1	30	✓	✓	100	30	56	58	100
113FAX01239S3D-100	Doppelverzahnung	2		8.000	1:1	30	✓	-	-	30	56	40	100
113GAX01239S3D-100	Double spline	2		8.000	1:1	30	✓	✓	100	30	56	58	100
113FAX01239S32-100	Doppelspindler Double spindle	3		8.000	1:1	30	✓	-	-	30	56	-	100

EK: externe Kühlung, IK: interne Kühlung  
R: rechte Ausführung, L: linke Ausführung  
Maß A: max. Länge inkl. Spannfutter  
Zubehör (ab S. 103) ist nicht im Lieferumfang enthalten.  
Technische Änderungen vorbehalten.

EC: external coolant, IC: internal coolant  
R: right hand design, L: left hand design  
Dimension A: max. length incl. clamping nut  
Accessories (from p. 103) are not included in delivery.  
We reserve the right to modify technical contents.

Sauter  
Revolver  
VDI 30

# Sauter Revolver VDI 30 / DIN 5480

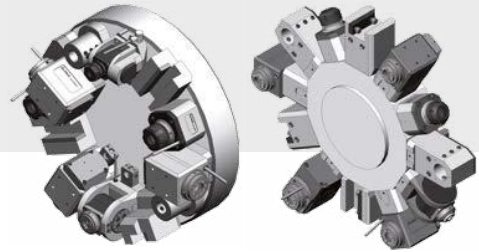

## Angetriebene Werkzeuge | Live Tools

### Spannzange | Collet Chuck

Bestell-Nr. Order No.	Ausführung Tool style	Bild Figure	Aufnahme Tool holder	n [min <sup>-1</sup> ]	Übersetzung Gear ratio	T [Nm]	EK EC	IK IC	pmax [bar]	Maße   Dimensions				
										D	A*	B	L	L <sub>4</sub>
113DA01200E5A	axial	1	ER25	8.000	1:1	25	✓	-	-	30	53,9	-	-	-
113EA01231E5A	axial	1	ER25	8.000	1:1	25	✓	✓	50	30	79,9	-	-	-
113FAX01239E5AR	radial	2	ER25	8.000	1:1	30	✓	-	-	30	56,9	40	55	-
113FAX01239E5AL	radial	2	ER25	8.000	1:1	30	✓	-	-	30	56,9	40	55	-
113GAX01239E5AR	radial	2	ER25	8.000	1:1	30	✓	✓	100	30	61,9	58	55	-
113GAX01239E5AL	radial	2	ER25	8.000	1:1	30	✓	✓	100	30	61,9	58	55	-
113FAX01239E5AR-80	radial	2	ER25	8.000	1:1	30	✓	-	-	30	56,9	40	80	-
113FAX01239E5AL-80	radial	2	ER25	8.000	1:1	30	✓	-	-	30	56,9	40	80	-
113GAX01239E5AR-80	radial	2	ER25	8.000	1:1	30	✓	✓	100	30	61,9	58	80	-
113GAX01239E5AL-80	radial	2	ER25	8.000	1:1	30	✓	✓	100	30	61,9	58	80	-
113FAX01239E5AD-80	Doppel- verzahnung	2	ER25	8.000	1:1	30	✓	-	-	30	56,9	40	80	-
113GAX01239E5AD-80	Double spline	2	ER25	8.000	1:1	30	✓	✓	100	30	61,9	58	80	-
113FAX01239E5A2-80	Doppelspindel Double spindle	3	ER25	8.000	1:1	30	✓	-	-	30	56,9	-	80	-
113FAX01239E5AR-100	radial	2	ER25	8.000	1:1	30	✓	-	-	30	56,9	40	100	-
113FAX01239E5AL-100	radial	2	ER25	8.000	1:1	30	✓	-	-	30	56,9	40	100	-
113GAX01239E5AR-100	radial	2	ER25	8.000	1:1	30	✓	✓	100	30	61,9	58	100	-
113GAX01239E5AL-100	radial	2	ER25	8.000	1:1	30	✓	✓	100	30	61,9	58	100	-
113FAX01239E5AD-100	Doppel- verzahnung	2	ER25	8.000	1:1	30	✓	-	-	30	56,9	40	100	-
113GAX01239E5AD-100	Double spline	2	ER25	8.000	1:1	30	✓	✓	100	30	61,9	58	100	-
113FAX01239E5A2-100	Doppelspindel Double spindle	3	ER25	8.000	1:1	30	✓	-	-	30	56,9	-	100	-
113FDX01239E3A	schwenkbar swiveling	4	ER16	8.000	1:0,88	12	✓	-	-	30	-	-	61	51,1
113GDX01239E3A	F= ±98°	4	ER16	8.000	1:0,88	12	✓	✓	50	30	-	-	61	56

EK: externe Kühlung, IK: interne Kühlung  
R: rechte Ausführung, L: linke Ausführung  
Maß A\*: max. Länge inkl. Spannmutter  
Zubehör (ab S. 103) ist nicht im Lieferumfang enthalten.  
Technische Änderungen vorbehalten.

EC: external coolant, IC: internal coolant  
R: right hand design, L: left hand design  
Dimension A\*: max. length incl. clamping nut  
Accessories (from p. 103) are not included in delivery.  
We reserve the right to modify technical contents.

# Sauter Revolver VDI 30 / DIN 5480



## Statische Halter | Static tool holder

Bestell-Nr. Order No.	Ausführung Tool style	Bild Figure	Maße   Dimensions			
			D <sub>1</sub>	h <sub>1</sub>	L <sub>1</sub>	L <sub>3</sub>
113.5552022	Vierkant-Queraufnahme rechts Square locking drive radial right	5	-	20x20	-	40
113.5562022	Vierkant-Queraufnahme links Square locking drive radial left	5	-	20x20	-	40
113.5592080	Vierkant-Queraufnahme   Square locking drive radial Haupt-, Gegenspindel, Überkopf   Main-, opposed spindle, overhead	6	-	20x20	-	80
113.55920110	Vierkant-Queraufnahme   Square locking drive radial Haupt-, Gegenspindel, Überkopf   Main-, opposed spindle, overhead	6	-	20x20	-	110
113.5612070	Vierkant-Längsaufnahme links   Turning Tool holder axial left	7	-	20x20	-	70
113.5622070	Vierkant-Längsaufnahme links   Turning Tool holder axial left	7	-	20x20	-	70
113.5672080	Vierkant-Längsaufnahme doppelt Turning Tool holder axial double Haupt-, Gegenspindel, Überkopf   Main-, opposed spindle, overhead	8	-	20x20	-	80
113.5712560	Bohrstangenhalter   Boring bar holder	9	Ø25	-	-	60
113A012578001	Bohrstangenhalter   Boring bar holder Haupt-, Gegenspindel mit IK   Main-, opposed spindle with IC	10	Ø25	-	80	-
113A012578002	Bohrstangenhalter   Boring bar holder Haupt-, Gegenspindel mit IK   Main-, opposed spindle with IC	10	Ø25	-	100	-

Weitere Ausführungen ab S. 92 | Additional models from p. 92

### Beispiele | Examples

Horizontaldrehmaschine mit Sternrevolver  
Horizontal lathe with star turret

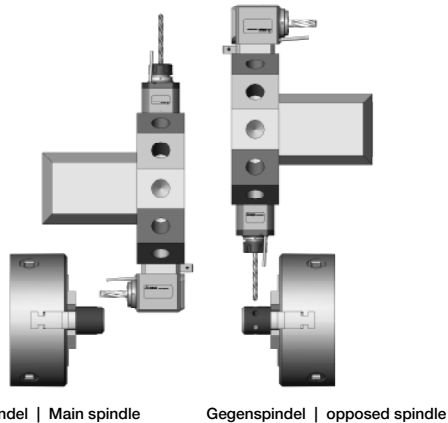

Hauptspindel | Main spindle

Gegenspindel | opposed spindle

Radialwerkzeug: L=80mm, linke Ausführung, EK, BENZ Solidfix® S3  
Radial live tool: L=80mm, left version, EC, BENZ Solidfix® S3  
> 113FAX01239S3L-80

Vertikaldrehmaschine mit Sternrevolver  
vertical lathe with star turret

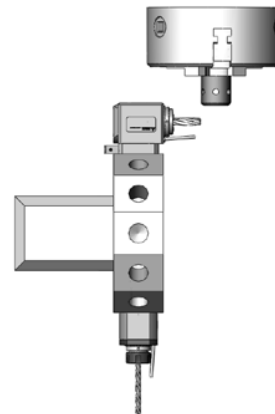

Radialwerkzeug: L=55mm, rechte Ausführung, IK, BENZ Solidfix® S3  
Radial live tool: L=55mm, right version, IC, BENZ Solidfix® S3  
> 113GAX01239S3R

Horizontaldrehmaschine mit Scheibenrevolver  
Horizontal lathe with disc turret

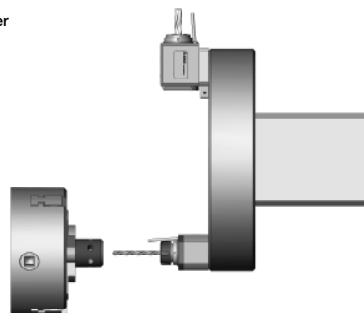

Radialwerkzeug: L=55mm, linke Ausführung, EK, BENZ Solidfix® S3  
Radial live tool: L=55mm, left version, EC, BENZ Solidfix® S3  
> 113FAX01239S3L

Sauter  
Revolver  
VDI 30

# Sauter Revolver VDI 30 / DIN 5482

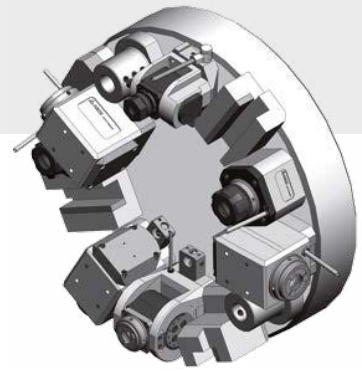

Colchester Tornado T6 M  
 Colchester Tornado T120 M  
 Emco Turn 360  
 Emco Turn 365  
 Gildemeister CTX 300  
 Gildemeister CTX 310 eco

Gildemeister CTX 400  
 Gildemeister CTX 400 E  
 Gildemeister CTX 400 Serie 2  
 Gildemeister NEF 520  
 Monforts RNC3

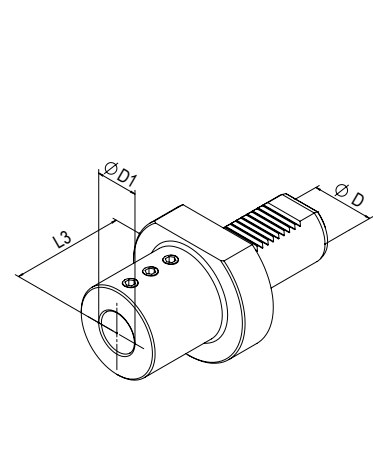
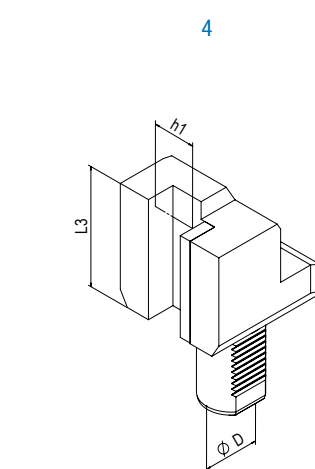
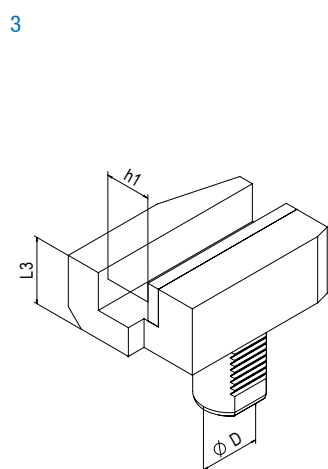
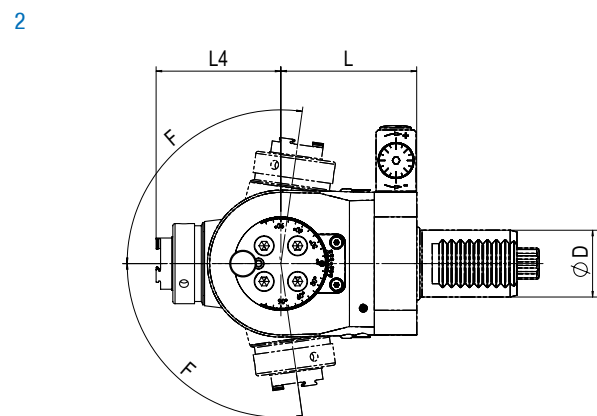
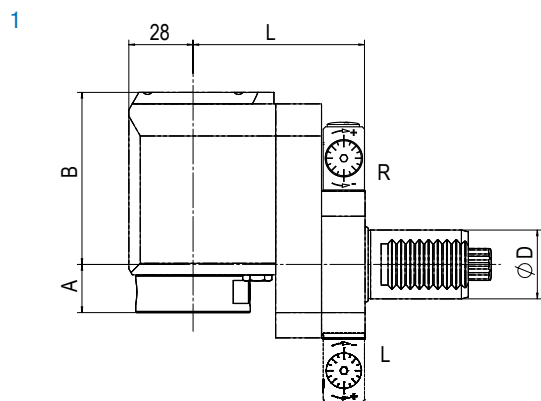
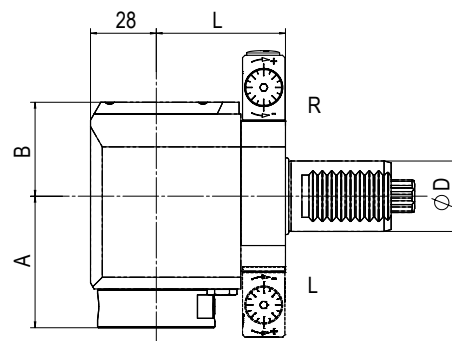
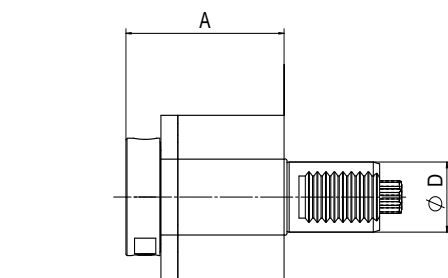

# Sauter Revolver VDI 30 / DIN 5482



## Angetriebene Werkzeuge | Live Tools

### BENZ Solidfix® Modulares Schnellwechselsystem | Modular Quick Change System

Bestell-Nr. Order No.	Ausführung Tool style	Bild Figure	Aufnahme Tool holder	n [min <sup>-1</sup> ]	Übersetzung Gear ratio	T [Nm]	EK EC	IK IC	pmax [bar]	Maße   Dimensions				
										D	A	B	L	L <sub>4</sub>
113DA00500S3	axial	1	BENZ Solidfix® S3	8.000	1:1	25	✓	-	-	30	58	-	-	-
113EA00531S3	axial	1		8.000	1:1	25	✓	✓	50	30	79	-	-	-
113FAX00539S3R	radial	2		8.000	1:1	30	✓	-	-	30	56	40	55	-
113FAX00539S3L	radial	2		8.000	1:1	30	✓	-	-	30	56	40	55	-
113GAX00539S3R	radial	2		8.000	1:1	30	✓	✓	100	30	56	58	55	-
113GAX00539S3L	radial	2		8.000	1:1	30	✓	✓		30	56	58	55	-
113FBX00539S3R	radial zurückgesetzt offset	3		8.000	1:1	30	✓	-	-	30	21	75	75	-
113FBX00539S3L		3		8.000	1:1	30	✓	-	-	30	21	75	75	-
113GBX00539S3R		3		8.000	1:1	30	✓	✓	100	30	21	93	75	-
113GBX00539S3L		3		8.000	1:1	30	✓	✓		30	21	93	75	-

Maß A: bis Plananlage, ohne Adapter | Dimension A: up to plane surface, without adapter

### Spannzange | Collet Chuck

Bestell-Nr. Order No.	Ausführung Tool style	Bild Figure	Aufnahme Tool holder	n [min <sup>-1</sup> ]	Übersetzung Gear ratio	T [Nm]	EK EC	IK IC	pmax [bar]	Maße   Dimensions				
										D	A*	B	L	L <sub>4</sub>
113DA00500E5A	axial	1	ER25	8.000	1:1	25	✓	-	-	30	53,9	-	-	-
113EA00531E5A	axial	1	ER25	8.000	1:1	25	✓	✓	50	30	79,9	-	-	-
113FAX00539E5AR	radial	2	ER25	8.000	1:1	30	✓	-	-	30	56,9	40	55	-
113FAX00539E5AL	radial	2	ER25	8.000	1:1	30	✓	-	-	30				-
113GAX00539E5AR	radial	2	ER25	8.000	1:1	30	✓	✓	100	30	61,9	58		-
113GAX00539E5AL	radial	2	ER25	8.000	1:1	30	✓	✓		30				-
113FBX00539E5AR	radial zurückgesetzt offset	3	ER25	8.000	1:1	30	✓	-	-	30	21,9	75	75	-
113FBX00539E5AL		3	ER25	8.000	1:1	30	✓	-	-	30				-
113GBX00539E5AR		3	ER25	8.000	1:1	30	✓	✓	100	30	26,9	93		-
113GBX00539E5AL		3	ER25	8.000	1:1	30	✓	✓		30				-
113FDX00539E3A	schwenkbar swiveling	4	ER16	8.000	1:0,88	12	✓	-	-	30	-	-	61	51,1
113GDX00539E3A	F = ±98°	4	ER16	8.000	1:0,88	12	✓	✓	50	30	-	-	61	56

EK: externe Kühlung, IK: interne Kühlung  
R: rechte Ausführung, L: linke Ausführung  
Maß A\*: max. Länge inkl. Spannmutter  
Zubehör (ab S. 103) ist nicht im Lieferumfang enthalten.  
Technische Änderungen vorbehalten.

EC: external coolant, IC: internal coolant  
R: right hand design, L: left hand design  
Dimension A\*: max. length incl. clamping nut  
Accessories (from p. 103) are not included in delivery.  
We reserve the right to modify technical contents.

Sauter  
Revolver  
VDI 30

### Statische Halter | Static tool holder

Bestell-Nr. Order No.	Ausführung Tool style	Bild Figure	Maße   Dimensions		
			D <sub>1</sub>	h <sub>1</sub>	L <sub>3</sub>
113.5552022	Viereck-Queraufnahme rechts   Square locking drive radial right	5	-	20x20	40
113.5562022	Viereck-Queraufnahme links   Square locking drive radial left	5	-	20x20	40
113.5612070	Viereck-Längsaufnahme rechts   Turning Tool holder axial right	6	-	20x20	70
113.5622070	Viereck-Längsaufnahme links   Turning Tool holder axial left	6	-	20x20	70
113.5712560	Bohrstangenhalter   Boring bar holder	7	Ø25	-	60

Weitere Ausführungen ab S. 92 | Additional models from p. 92



# Sauter Revolver VDI 40 / DIN 5480

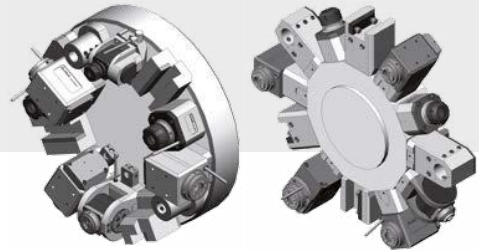

Boehring NG 180-2  
 Boehring NG 200-L  
 Gildemeister CTV 160  
 Gildemeister CTV 200  
 Gildemeister CTV 250  
 Gildemeister CTX 410  
 Gildemeister CTX 420 linear  
 Gildemeister CTX 510  
 Gildemeister CTX 520 linear

Gildemeister CTX beta 500  
 Gildemeister CTX beta 800  
 Gildemeister CTX beta 1250  
 Gildemeister GMX 250 linear  
 Gildemeister GMX 250 S linear  
 Gildemeister GMX 300  
 Gildemeister GMX 400  
 Gildemeister GMX 500  
 Gildemeister Twin 102

Gildemeister Twin 500  
 HURCO TMX 8MY/MYS  
 HURCO TMM 10  
 Monforts DNC 5  
 Monforts DNC 400 5  
 Monforts RNC 400 DUO  
 Monforts RNC 500 DUO  
 Monforts RNC 600 DUO

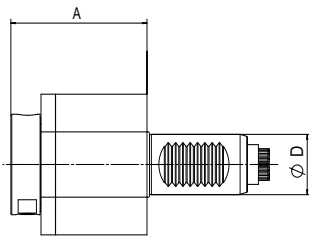

1

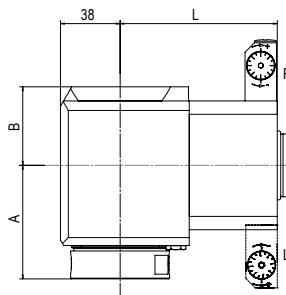

2

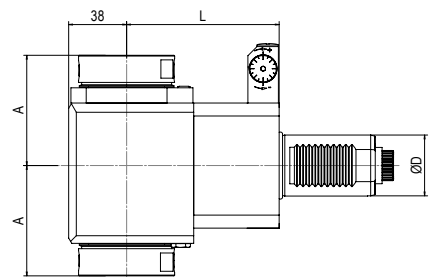

3

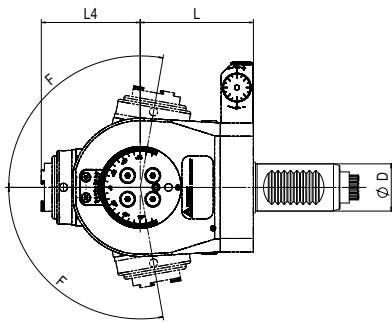

4

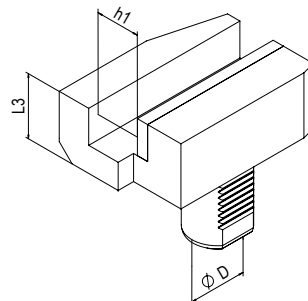

5

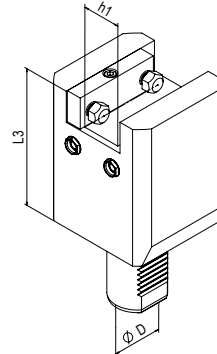

6

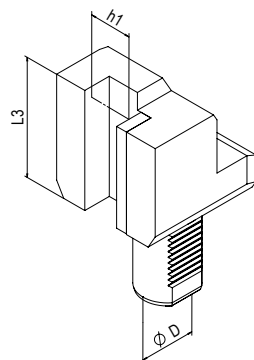

7

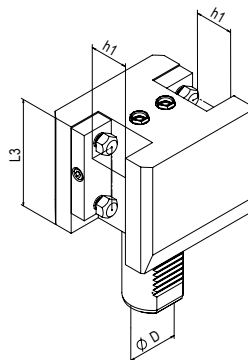

8

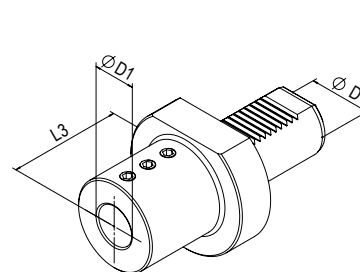

9

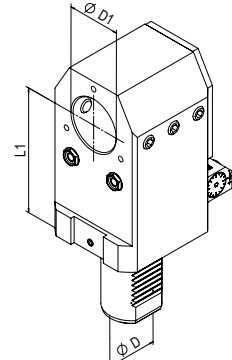

10

# Sauter Revolver VDI 40 / DIN 5480



## Angetriebene Werkzeuge | Live Tools

### BENZ Solidfix® Modulares Schnellwechselsystem | Modular Quick Change System

Bestell-Nr. Order No.	Ausführung Tool style	Bild Figure	Aufnahme Tool holder	n [min <sup>-1</sup> ]	Übersetzung Gear ratio	T [Nm]	EK EC	IK IC	pmax [bar]	Maße   Dimensions			
										D	A	B	L
114DA03541S4	axial	1		6.000	1:1	50	✓	-	-	40	88	-	-
114EA03541S4	axial	1		6.000	1:1	50	✓	✓	50	40	88	-	-
114FAX03549S4R	radial	2		6.000	1:1	70	✓	-	-	40	72	50	65
114FAX03549S4L	radial	2		6.000	1:1	70	✓	-	-	40	72	50	65
114GAX03549S4R	radial	2		6.000	1:1	70	✓	✓	100	40	72	60	65
114GAX03549S4L	radial	2		6.000	1:1	70	✓	✓	100	40	72	50	65
114FAX03549S4R-100	radial	2		6.000	1:1	70	✓	-	-	40	72	50	100
114FAX03549S4L-100	radial	2		6.000	1:1	70	✓	-	-	40	72	50	100
114GAX03549S4R-100	radial	2		6.000	1:1	70	✓	✓	100	40	72	60	100
114GAX03549S4L-100	radial	2		6.000	1:1	70	✓	✓	100	40	72	60	100
114FAX03549S4D-100	Doppel- verzahnung	2	BENZ Solidfix® S4	6.000	1:1	70	✓	-	-	40	72	50	100
114GAX03549S4D-100	Double spline	2		6.000	1:1	70	✓	✓	100	40	72	60	100
114FAX03549S42-100	Doppelspindler Double spindle	3		6.000	1:1	70	✓	-	-	40	72	-	100
114FAX03549S4R-120	radial	2		6.000	1:1	70	✓	-	-	40	72	50	120
114FAX03549S4L-120	radial	2		6.000	1:1	70	✓	-	-	40	72	50	120
114GAX03549S4R-120	radial	2		6.000	1:1	70	✓	✓	100	40	72	60	120
114GAX03549S4L-120	radial	2		6.000	1:1	70	✓	✓	100	40	72	60	120
114FAX03549S4D-120	Doppel- verzahnung	2		6.000	1:1	70	✓	-	-	40	72	50	120
114GAX03549S4D-120	Double spline	2		6.000	1:1	70	✓	✓	100	40	72	60	120
114FAX03549S42-120	Doppelspindler Double spindle	3		6.000	1:1	70	✓	-	-	40	72	-	120

EK: externe Kühlung, IK: interne Kühlung  
R: rechte Ausführung, L: linke Ausführung  
Zubehör (ab S. 103) ist nicht im Lieferumfang enthalten.  
Technische Änderungen vorbehalten.

EC: external coolant, IC: internal coolant  
R: right hand design, L: left hand design  
Accessories (from p. 103) are not included in delivery.  
We reserve the right to modify technical contents.

Sauter  
Revolver  
VDI 40

# Sauter Revolver VDI 40 / DIN 5480

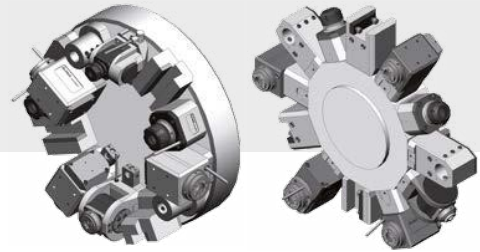

## Angetriebene Werkzeuge | Live Tools

### Spannzange | Collet Chuck

Bestell-Nr. Order No.	Ausführung Tool style	Bild Figure	Aufnahme Tool holder	n [min <sup>-1</sup> ]	Übersetzung Gear ratio	T [Nm]	EK EC	IK IC	pmax [bar]	Maße   Dimensions				
										D	A*	B	L	L <sub>4</sub>
114DA03541E6A	axial	1	ER32	6.000	1:1	50	✓	-	-	40	76,1	-	-	-
114EA03541E6A	axial	1	ER32	6.000	1:1	50	✓	✓	50	40	81,2	-	-	-
114FAX03549E6AR	radial	2	ER32	6.000	1:1	70	✓	-	-	40	71,1	50	65	-
114FAX03549E6AL	radial	2	ER32	6.000	1:1	70	✓	-	-	40	71,1	50	65	-
114GAX03549E6AR	radial	2	ER32	6.000	1:1	70	✓	✓	100	40	76,2	60	65	-
114GAX03549E6AL	radial	2	ER32	6.000	1:1	70	✓	✓	100	40	76,2	60	65	-
114FAX03549E6AR-100	radial	2	ER32	6.000	1:1	70	✓	-	-	40	71,1	50	100	-
114FAX03549E6AL-100	radial	2	ER32	6.000	1:1	70	✓	-	-	40	71,1	50	100	-
114GAX03549E6AR-100	radial	2	ER32	6.000	1:1	70	✓	✓	100	40	76,2	60	100	-
114GAX03549E6AL-100	radial	2	ER32	6.000	1:1	70	✓	✓	100	40	76,2	60	100	-
114FAX03549E6AD-100	Doppel- verzahnung	2	ER32	6.000	1:1	70	✓	-	-	40	71,1	50	100	-
114GAX03549E6AD-100	Double spline	2	ER32	6.000	1:1	70	✓	✓	100	40	76,2	60	100	-
114FAX03549E6A2-100	Doppelspindler Double spindle	3	ER32	6.000	1:1	70	✓	-	-	40	71,1	-	100	-
114FAX03549E6AR-120	radial	2	ER32	6.000	1:1	70	✓	-	-	40	71,1	50	120	-
114FAX03549E6AL-120	radial	2	ER32	6.000	1:1	70	✓	-	-	40	71,1	50	120	-
114GAX03549E6AR-120	radial	2	ER32	6.000	1:1	70	✓	✓	100	40	76,2	60	120	-
114GAX03549E6AL-120	radial	2	ER32	6.000	1:1	70	✓	✓	100	40	76,2	60	120	-
114FAX03549E6AD-120	Doppel- verzahnung	2	ER32	6.000	1:1	70	✓	-	-	40	71,1	50	120	-
114GAX03549E6AD-120	Double spline	2	ER32	6.000	1:1	70	✓	✓	100	40	76,2	60	120	-
114FAX03549E6A2-120	Doppelspindler Double spindle	3	ER32	6.000	1:1	70	✓	-	-	40	71,1	-	120	-
114FDX03549E5A	schwenkbar swiveling	4	ER25	6.000	1:0,82	32	✓	-	-	40	-	-	72	57,9
114GDX03549E5A	F= ±100°		ER25	6.000	1:0,82	32	✓	✓	50	40	-	-	72	62,9

EK: externe Kühlung, IK: interne Kühlung  
R: rechte Ausführung, L: linke Ausführung  
Maß A\*: max. Länge inkl. Spannmutter  
Zubehör (ab S. 103) ist nicht im Lieferumfang enthalten.  
Technische Änderungen vorbehalten.

EC: external coolant, IC: internal coolant  
R: right hand design, L: left hand design  
Dimension A\*: max. length incl. clamping nut  
Accessories (from p. 103) are not included in delivery.  
We reserve the right to modify technical contents.

# Sauter Revolver VDI 40 / DIN 5480



## Statische Halter | Static tool holder

Bestell-Nr. Order No.	Ausführung Tool style	Bild Figure	Maße   Dimensions			
			D <sub>1</sub>	h <sub>1</sub>	L <sub>1</sub>	L <sub>3</sub>
114.5552522	Vierkant-Queraufnahme rechts Square locking drive radial right	5	-	25x25	-	44
114.5562522	Vierkant-Queraufnahme links Square locking drive radial left	5	-	25x25	-	44
114.55925100	Vierkant-Queraufnahme   Square locking drive radial Haupt-, Gegenspindel, Überkopf   Main-, opposed spindle, overhead	6	-	25x25	-	100
114.55925120	Vierkant-Queraufnahme   Square locking drive radial Haupt-, Gegenspindel, Überkopf   Main-, opposed spindle, overhead	6	-	25x25	-	120
114.5612585	Vierkant-Längsaufnahme rechts   Turning Tool holder axial right	7	-	25x25	-	85
114.5622585	Vierkant-Längsaufnahme links   Turning Tool holder axial left	7	-	25x25	-	85
114.5672580	Vierkant-Längsaufnahme doppelt Turning Tool holder axial left double Haupt-, Gegenspindel, Überkopf   Main-, opposed spindle, overhead	8	-	25x25	-	80
114.5713275	Bohrstangenhalter   Boring bar holder	9	Ø32	-	-	75
114A035578001	Bohrstangenhalter   Boring bar holder Haupt-, Gegenspindel mit IK   Main-, opposed spindle with IC	10	Ø40	-	100	-
114A035578002	Bohrstangenhalter   Boring bar holder Haupt-, Gegenspindel mit IK   Main-, opposed spindle with IC	10	Ø32	-	120	-
114A035578003	Bohrstangenhalter   Boring bar holder Haupt-, Gegenspindel mit IK   Main-, opposed spindle with IC	10	Ø32	-	100	-

Weitere Ausführungen ab S. 92 | Additional models from p. 92

### Beispiele | Examples

Horizontaldrehmaschine mit Sternrevolver  
Horizontal lathe with star turret

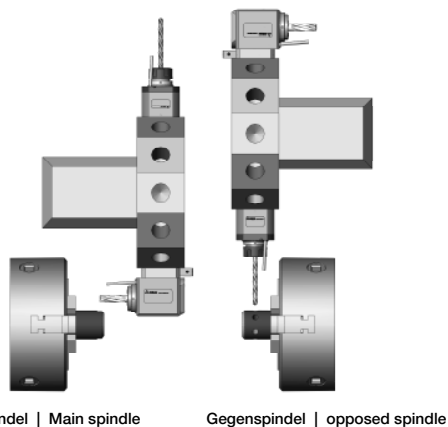

Hauptspindel | Main spindle

Gegenspindel | opposed spindle

Radialwerkzeug: L=120mm, linke Ausführung, EK, BENZ Solidfix® S4  
Radial live tool: L=120mm, left version, EC, BENZ Solidfix® S4  
> 114FAX035499S4L-120

Vertikaldrehmaschine mit Sternrevolver  
vertical lathe with star turret

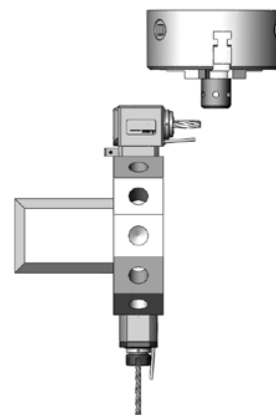

Radialwerkzeug: L=65mm, rechte Ausführung, IK, BENZ Solidfix® S4  
Radial live tool: L=65mm, right version, IC, BENZ Solidfix® S4  
> 114GAX03549S4R

Horizontaldrehmaschine mit Scheibenrevolver  
Horizontal lathe with disc turret

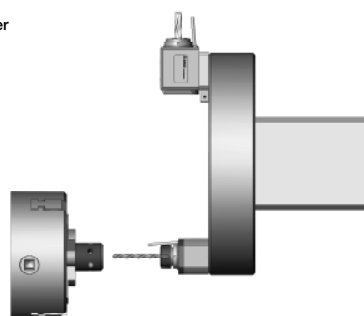

Radialwerkzeug: L=65mm, linke Ausführung, EK, BENZ Solidfix® S4  
Radial live tool: L=120mm, left version, EC, BENZ Solidfix® S4  
> 114FAX03549S4L

Sauter  
Revolver  
VDI 40

# Sauter Revolver VDI 40 / DIN 5482

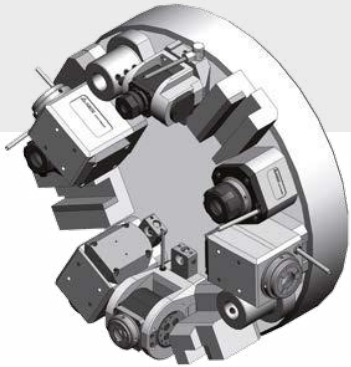

Gildemeister CTX 400  
 Gildemeister CTX 500  
 Graziano GR 400 C  
 Monforts RNC 4

Monforts RNC 5  
 Monforts RNC 400  
 Monforts RNC 500  
 Monforts RNC 600

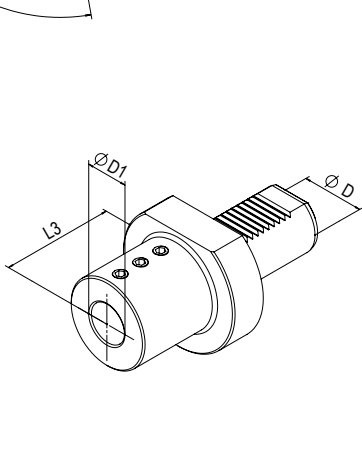
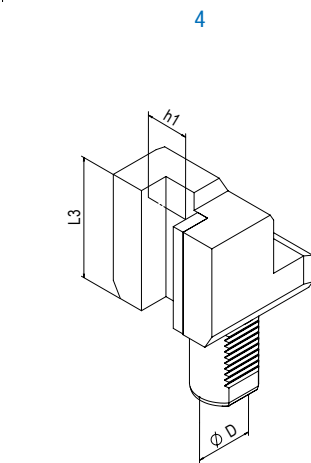
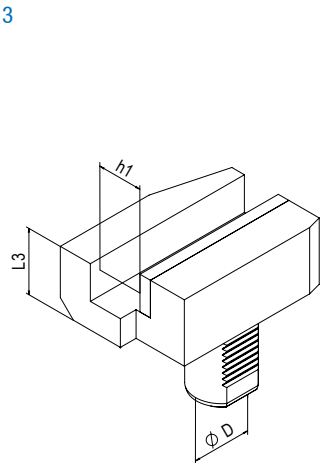
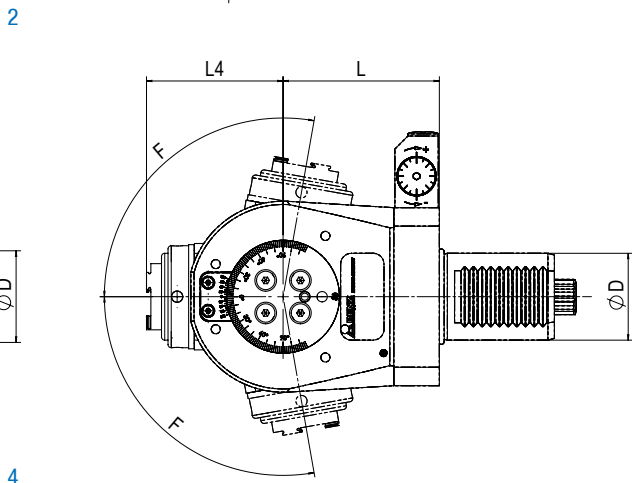
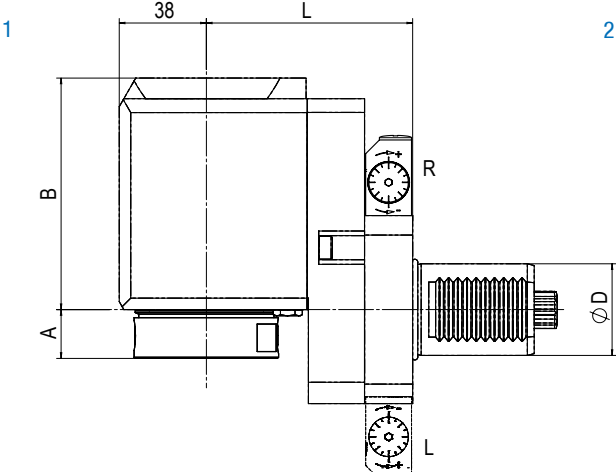
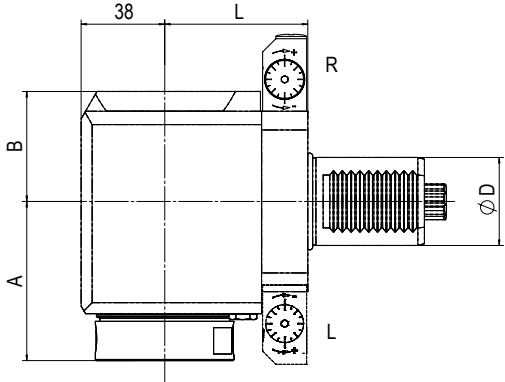
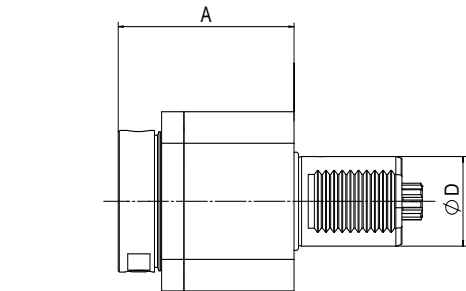

# Sauter Revolver VDI 40 / DIN 5482



## Angetriebene Werkzeuge | Live Tools

### BENZ Solidfix® Modulares Schnellwechselsystem | Modular Quick Change System

Bestell-Nr. Order No.	Ausführung Tool style	Bild Figure	Aufnahme Tool holder	n [min <sup>-1</sup> ]	Übersetzung Gear ratio	T [Nm]	EK EC	IK IC	pmax [bar]	Maße   Dimensions				
										D	A	B	L	L <sub>4</sub>
114DA01341S4	axial	1	BENZ Solidfix® S4	6.000	1:1	50	✓	-	-	40	88	-	-	-
114EA01341S4	axial	1		6.000	1:1	50	✓	✓	50	40	88	-	-	-
114FAX01349S4R	radial	2		6.000	1:1	70	✓	-	-	40	72	50	65	-
114FAX01349S4L	radial	2		6.000	1:1	70	✓	-	-	40	72	50	65	-
114GAX01349S4R	radial	2		6.000	1:1	70	✓	✓	100	40	72	60	65	-
114GAX01349S4L	radial	2		6.000	1:1	70	✓	✓	100	40	72	60	65	-
114FBX01349S4R	radial zurückgesetzt offset	3		6.000	1:1	70	✓	-	-	40	21	101	90	-
114FBX01349S4L		3		6.000	1:1	70	✓	-	-	40	21	101	90	-
114GBX01349S4R		3		6.000	1:1	70	✓	✓	100	40	21	111	90	-
114GBX01349S4L		3		6.000	1:1	70	✓	✓	100	40	21	111	90	-

Maß A: bis Plananlage, ohne Adapter | Dimension A: up to plane surface, without adapter

## Spannzange | Collet Chuck

Bestell-Nr. Order No.	Ausführung Tool style	Bild Figure	Aufnahme Tool holder	n [min <sup>-1</sup> ]	Übersetzung Gear ratio	T [Nm]	EK EC	IK IC	pmax [bar]	Maße   Dimensions				
										D	A*	B	L	L <sub>4</sub>
114DA01341E6A	axial	1	ER32	6.000	1:1	50	✓	-	-	40	76,1	-	-	-
114EA01341E6A	axial	1	ER32	6.000	1:1	50	✓	✓	50	40	81,2	-	-	-
114FAX01349E6AR	radial	2	ER32	6.000	1:1	70	✓	-	-	40	71,1	50	65	-
114FAX01349E6AL	radial	2	ER32	6.000	1:1	70	✓	-	-	40	71,1	50	65	-
114GAX01349E6AR	radial	2	ER32	6.000	1:1	70	✓	✓	100	40	76,2	60	65	-
114GAX01349E6AL	radial	2	ER32	6.000	1:1	70	✓	✓	100	40	76,2	60	65	-
114FBX01349E6AR	radial zurückgesetzt offset	3	ER32	6.000	1:1	70	✓	-	-	40	20,1	101	90	-
114FBX01349E6AL		3	ER32	6.000	1:1	70	✓	-	-	40	20,1	101	90	-
114GBX01349E6AR		3	ER32	6.000	1:1	70	✓	✓	100	40	25,2	111	90	-
114GBX01349E6AL		3	ER32	6.000	1:1	70	✓	✓	100	40	25,2	111	90	-
114FDX01349E5A	schwenkbar swiveling	4	ER25	6.000	1:0,82	32	✓	-	-	40	-	-	72	57,9
114GDX01349E5A	F = ±100°	4	ER25	6.000	1:0,82	32	✓	✓	50	40	-	-	72	62,9

EK: externe Kühlung, IK: interne Kühlung  
R: rechte Ausführung, L: linke Ausführung  
Maß A\*: max. Länge inkl. Spannmutter  
Zubehör (ab S. 103) ist nicht im Lieferumfang enthalten.  
Technische Änderungen vorbehalten.

EC: external coolant, IC: internal coolant  
R: right hand design, L: left hand design  
Dimension A\*: max. length incl. clamping nut  
Accessories (from p. 103) are not included in delivery.  
We reserve the right to modify technical contents.

Sauter  
Revolver  
VDI 40

## Statische Halter | Static tool holder

Bestell-Nr. Order No.	Ausführung Tool style	Bild Figure	Maße   Dimensions		
			D <sub>1</sub>	h <sub>1</sub>	L <sub>3</sub>
114.5552522	Vierkant-Queraufnahme rechts   Square locking drive radial right	5	-	25x25	44
114.5562522	Vierkant-Queraufnahme links   Square locking drive radial left	5	-	25x25	44
114.5612585	Vierkant-Längsaufnahme rechts   Turning Tool holder axial right	6	-	25x25	85
114.5622585	Vierkant-Längsaufnahme links   Turning Tool holder axial left	6	-	25x25	85
114.5713275	Bohrstangenhalter   Boring bar holder	7	Ø32	-	75

Weitere Ausführungen ab S. 92 | Additional models from p. 92

# Sauter Revolver VDI 50 / DIN 5480

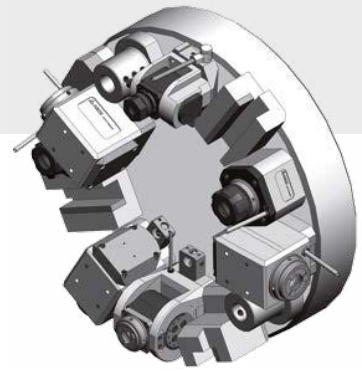

EMCO Maxxturn 110  
 Gildemeister CTX 520 linear  
 Gildemeister CTX 620 linear  
 Gildemeister CTX 620 linear mit y-Achse

Gildemeister CTX gamma 1250  
 Gildemeister CTX gamma 2000  
 Weiler E 110

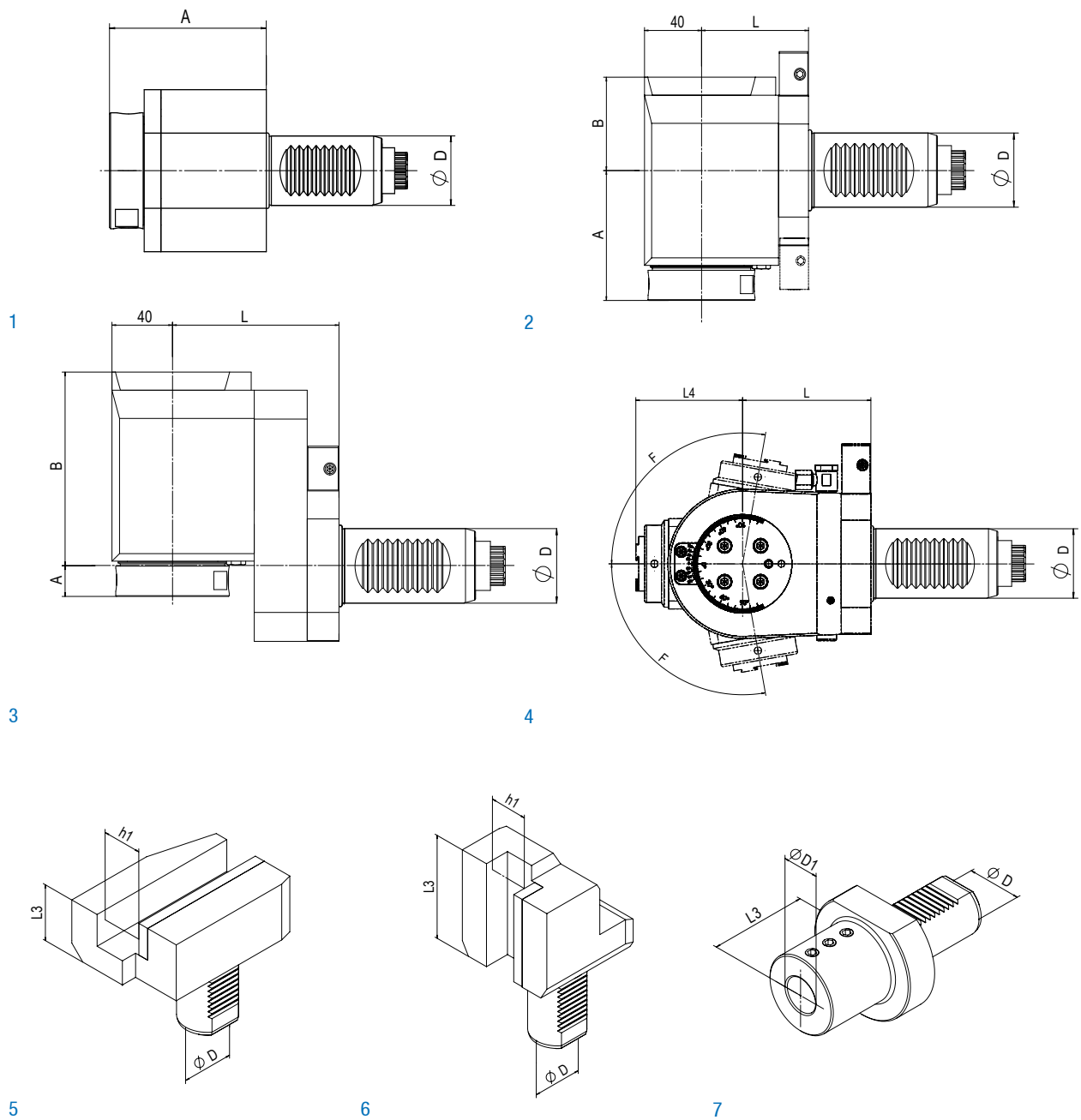

# Sauter Revolver VDI 50 / DIN 5480



## Angetriebene Werkzeuge | Live Tools

### BENZ Solidfix® Modulares Schnellwechselsystem | Modular Quick Change System

Bestell-Nr. Order No.	Ausführung Tool style	Bild Figure	Aufnahme Tool holder	n [min <sup>-1</sup> ]	Übersetzung Gear ratio	T [Nm]	EK EC	IK IC	pmax [bar]	Maße   Dimensions				
										D	A	B	L	L <sub>4</sub>
115DA03251S5	axial	1	BENZ Solidfix® S5	4.500	1:1	100	✓	-	-	50	93	-	-	-
115EA03251S5	axial	1		4.500	1:1	100	✓	✓	50	50	93	-	-	-
115FAX03259S5R	radial	2		4.500	1:1	150	✓	-	-	50	86	62	75	-
115GAX03259S5R	radial	2		4.500	1:1	150	✓	✓	100	50	86	68	75	-
115FBX03259S5R	radial	3		4.500	1:1	150	✓	-	-	50	20	128	110	-
115GBX03259S5R	zurückgesetzt	3		4.500	1:1	150	✓	✓	100	50	20	134	110	-

Maß A: bis Plananlage, ohne Adapter | Dimension A: up to plane surface, without adapter

## Spannzange | Collet Chuck

Bestell-Nr. Order No.	Ausführung Tool style	Bild Figure	Aufnahme Tool holder	n [min <sup>-1</sup> ]	Übersetzung Gear ratio	T [Nm]	EK EC	IK IC	pmax [bar]	Maße   Dimensions				
										D	A*	B	L	L <sub>4</sub>
115DA03251E7A	axial	1	ER40	4.500	1:1	100	✓	-	-	50	88,5	-	-	-
115EA03251E7A	axial	1	ER40	4.500	1:1	100	✓	✓	50	50	93,5	-	-	-
115FAX03259E7AR	radial	2	ER40	4.500	1:1	150	✓	-	-	50	81,5	62	75	-
115GAX03259E7AR	radial	2	ER40	4.500	1:1	150	✓	✓	100	50	86,4	68	75	-
115FBX03259E7AR	radial	3	ER40	4.500	1:1	150	✓	-	-	50	15,5	128	110	-
115GBX03259E7AR	zurückgesetzt offset	3	ER40	4.500	1:1	150	✓	✓	100	50	20,4	134	110	-
115FDX03259E6A	schwenkbar swiveling	4	ER32	6.000	1:0,82	70	✓	-	-	50	-	-	91	70,6
115GDX03259E6A	F= ±100°	4	ER32	6.000	1:0,82	70	✓	✓	50	50	-	-	91	75,7

EK: externe Kühlung, IK: interne Kühlung  
R: rechte Ausführung, L: linke Ausführung  
Maß A\*: max. Länge inkl. Spannmutter  
Zubehör (ab S. 103) ist nicht im Lieferumfang enthalten.  
Technische Änderungen vorbehalten.

EC: external coolant, IC: internal coolant  
R: right hand design, L: left hand design  
Dimension A\*: max. length incl. clamping nut  
Accessories (from p. 103) are not included in delivery.  
We reserve the right to modify technical contents.

Sauter  
Revolver  
VDI 50

## Statische Halter | Static tool holder

Bestell-Nr. Order No.	Ausführung Tool style	Bild Figure	Maße   Dimensions		
			D <sub>1</sub>	h <sub>1</sub>	L <sub>3</sub>
115.5553230	Vierkant-Queraufnahme rechts   Square locking drive radial right	5	-	32x32	55
115.56132100	Vierkant-Längsaufnahme rechts   Turning Tool holder axial right	6	-	32x32	100
115.5714090	Bohrstangenhalter   Boring bar holder	7	Ø40	-	90

Weitere Ausführungen ab S. 92 | Additional models from p. 92



# Sauter Revolver VDI 50 / DIN 5482

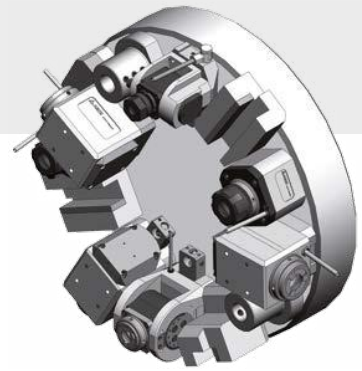

Daewoo V 500  
 Gildemeister CTX 600  
 Gildemeister CTX 700  
 Heid S 500

Heyligenstaedt Heynumat 15  
 WFL Millturn M 60 G (Revolver)  
 WFL WNC 500

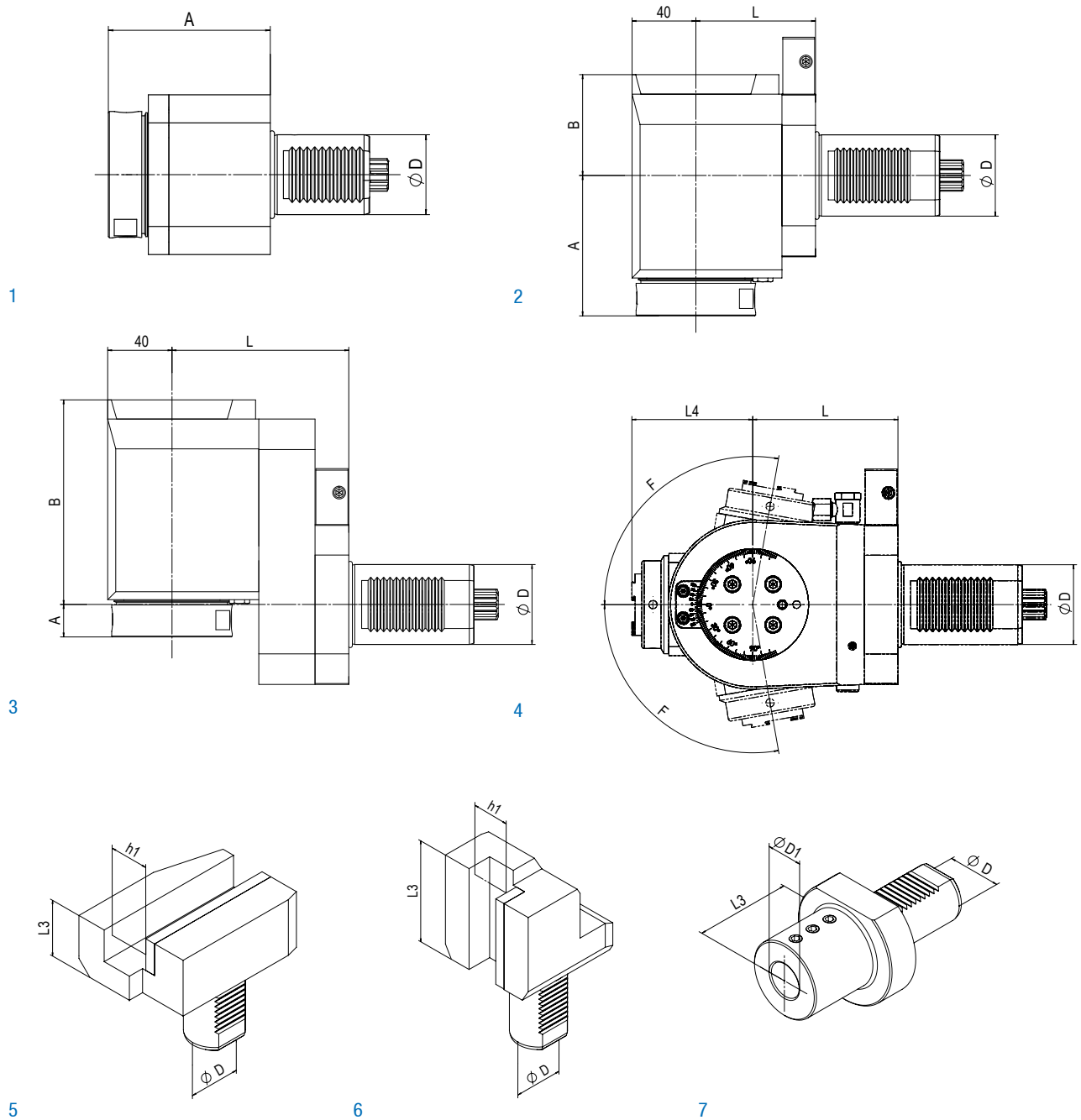

# Sauter Revolver VDI 50 / DIN 5482



## Angetriebene Werkzeuge | Live Tools

### BENZ Solidfix® Modulares Schnellwechselsystem | Modular Quick Change System

Bestell-Nr. Order No.	Ausführung Tool style	Bild Figure	Aufnahme Tool holder	n [min <sup>-1</sup> ]	Übersetzung Gear ratio	T [Nm]	EK EC	IK IC	pmax [bar]	Maße   Dimensions				
										D	A	B	L	L <sub>4</sub>
115DA00351S5	axial	1	BENZ Solidfix® S5	4.500	1:1	100	✓	-	-	50	93	-	-	-
115EA00351S5	axial	1		4.500	1:1	100	✓	✓	50	50	93	-	-	-
115FAX00359S5R	radial	2		4.500	1:1	150	✓	-	-	50	86	62	75	-
115GAX00359S5R	radial	2		4.500	1:1	150	✓	✓	100	50	86	68	75	-
115FBX00359S5R	radial	3		4.500	1:1	150	✓	-	-	50	20	128	110	-
115GBX00359S5R	zurückgesetzt	3		4.500	1:1	150	✓	✓	100	50	20	134	110	-

Maß A: bis Plananlage, ohne Adapter | Dimension A: up to plane surface, without adapter

## Spannzange | Collet Chuck

Bestell-Nr. Order No.	Ausführung Tool style	Bild Figure	Aufnahme Tool holder	n [min <sup>-1</sup> ]	Übersetzung Gear ratio	T [Nm]	EK EC	IK IC	pmax [bar]	Maße   Dimensions				
										D	A*	B	L	L <sub>4</sub>
115DA00351E7A	axial	1	ER40	4.500	1:1	100	✓	-	-	50	88,5	-	-	-
115EA00351E7A	axial	1	ER40	4.500	1:1	100	✓	✓	50	50	93,5	-	-	-
115FAX00359E7AR	radial	2	ER40	4.500	1:1	150	✓	-	-	50	81,5	62	75	-
115GAX00359E7AR	radial	2	ER40	4.500	1:1	150	✓	✓	100	50	86,4	68	75	-
115FBX00359E7AR	radial	3	ER40	4.500	1:1	150	✓	-	-	50	15,5	128	110	-
115GBX00359E7AR	zurückgesetzt offset	3	ER40	4.500	1:1	150	✓	✓	100	50	20,4	134	110	-
115FDX00359E6A	schwenkbar swiveling	4	ER32	6.000	1:0,82	70	✓	-	-	50	-	-	91	70,6
115GDX00359E6A	F= ±100°	4	ER32	6.000	1:0,82	70	✓	✓	50	50	-	-	91	75,7

EK: externe Kühlung, IK: interne Kühlung  
R: rechte Ausführung, L: linke Ausführung  
Maß A\*: max. Länge inkl. Spannmutter  
Zubehör (ab S. 103) ist nicht im Lieferumfang enthalten.  
Technische Änderungen vorbehalten.

EC: external coolant, IC: internal coolant  
R: right hand design, L: left hand design  
Dimension A\*: max. length incl. clamping nut  
Accessories (from p. 103) are not included in delivery.  
We reserve the right to modify technical contents.

Sauter  
Revolver  
VDI 50

## Statische Halter | Static tool holder

Bestell-Nr. Order No.	Ausführung Tool style	Bild Figure	Maße   Dimensions		
			D <sub>1</sub>	h <sub>1</sub>	L <sub>3</sub>
115.5553230	Viereck-Queraufnahme rechts   Square locking drive radial right	5	-	32x32	55
115.56132100	Viereck-Längsaufnahme rechts   Turning Tool holder axial right	6	-	32x32	100
115.5714090	Bohrstangenhalter   Boring bar holder	7	Ø40	-	90

Weitere Ausführungen ab S. 92 | Additional models from p. 92