

Nakamura Ø55



Nakamura SC-250
 Nakamura TMC 18
 Nakamura TW 10
 Nakamura TW 41

Nakamura WT 20
 Nakamura WT 150
 Nakamura WT 250
 Nakamura-Tome Super

NTJ
 Nakamura-Tome Super NTM 3

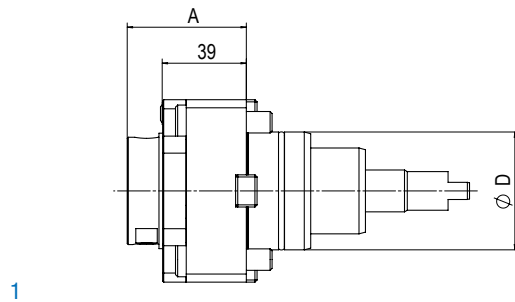

1

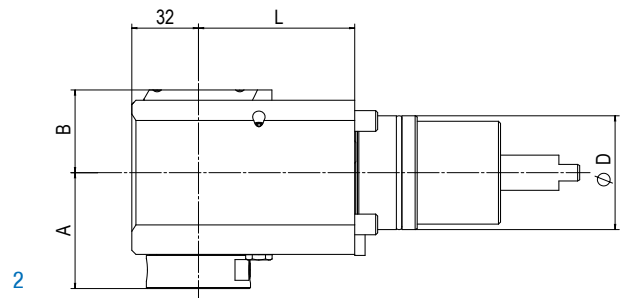

2

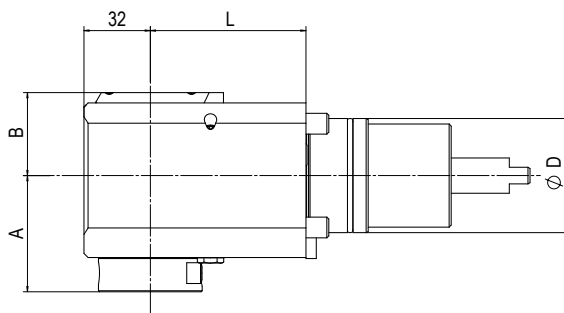

3

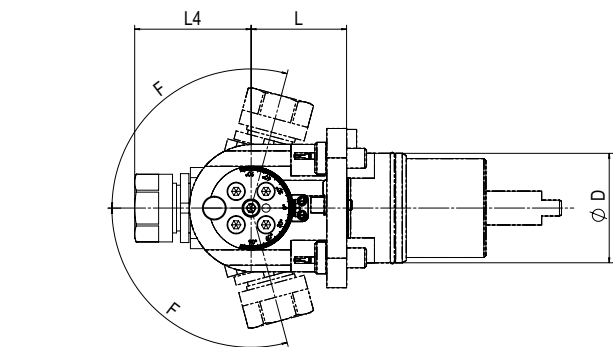

4

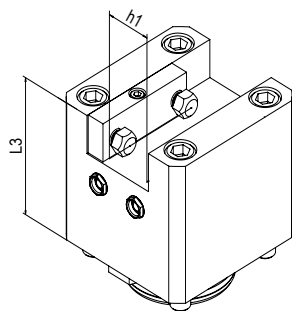

5

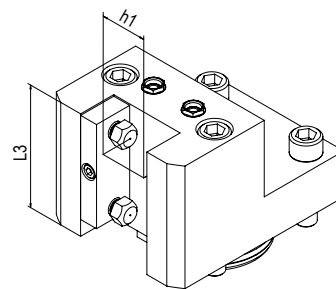

6

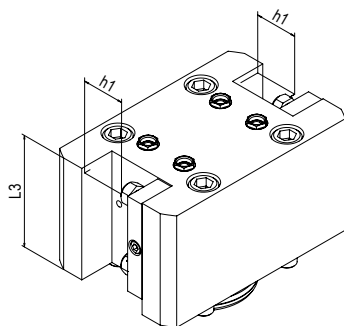

7

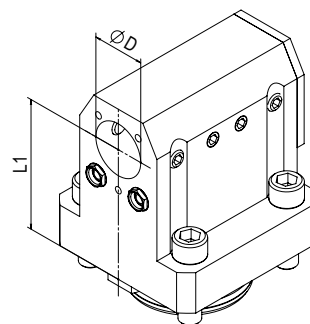

8



Angetriebene Werkzeuge | Live Tools

BENZ Solidfix® Modulares Schnellwechselsystem | Modular Quick Change System

Bestell-Nr. Order No.	Ausführung Tool style	Bild Figure	Aufnahme Tool holder	n [min ⁻¹]	Übersetzung Gear ratio	T [Nm]	EK EC	IK IC	pmax [bar]	Maße Dimensions				
										D	A	B	L	L ₄
113DA01500S3	axial	1	BENZ Solidfix® S3	8.000	1:1	25	✓	-	-	55	46	-	-	-
113EA01500S3	axial	1		8.000	1:1	25	✓	✓	50	55	46	-	-	-
113FAX01539S3D-75	radial	2		8.000	1:1	30	✓	-	-	55	56	40	75	-
113GAX01539S3D-75	radial	2		8.000	1:1	30	✓	✓	100	55	56	58	75	-
113FAX01539S32-75	Doppelspindel Double spindle	3		8.000	1:1	30	✓	-	-	55	56	-	75	-

Maß A: bis Plananlage, ohne Adapter | Dimension A: up to plane surface, without adapter

Spannzange | Collet Chuck

Bestell-Nr. Order No.	Ausführung Tool style	Bild Figure	Aufnahme Tool holder	n [min ⁻¹]	Übersetzung Gear ratio	T [Nm]	EK EC	IK IC	pmax [bar]	Maße Dimensions				
										D	A*	B	L	L ₄
113DA01500E5A	axial	1	ER 25	8.000	1:1	25	✓	-	-	55	48,8	-	-	-
113EA01500E5A	axial	1	ER 25	8.000	1:1	25	✓	✓	50	55	53,9	-	-	-
113FAX01539E5AD-75	radial	2	ER 25	8.000	1:1	30	✓	-	-	55	56,9	40	75	-
113GAX01539E5AD-75	radial	2	ER 25	8.000	1:1	30	✓	✓	100	55	61,9	58	75	-
113FAX01539E5A2-75	radial Doppelspindel Double spindle	3	ER 25	8.000	1:1	30	✓	-	-	55	56,9	-	75	-
113FK01538E3	schwenkbar swiveling F= ±105°	4	ER 16	8.000	1:2	8	✓	-	-	55			53	50,6

EK: externe Kühlung, IK: interne Kühlung
R: rechte Ausführung, L: linke Ausführung
Maß A*: max. Länge inkl. Spannmutter
Zubehör (ab S. 103) ist nicht im Lieferumfang enthalten.
Technische Änderungen vorbehalten.

EC: external coolant, IC: internal coolant
R: right hand design, L: left hand design
Dimension A*: max. length incl. clamping nut
Accessories (from p. 103) are not included in delivery.
We reserve the right to modify technical contents.

Statische Halter | Static tool holder

Bestell-Nr. Order No.	Ausführung Tool style	Bild Figure	Maße Dimensions			
			D ₁	h ₁	L ₁	L ₃
113A015559001	Viereck-Queraufnahme Square locking drive radial Haupt-, Gegenspindel, Überkopf Main-, opposed spindle, overhead	5	-	20x20	-	75
113A015560001	Viereck-Längsaufnahme Turning Tool holder axial Haupt-, Gegenspindel, Überkopf Main-, opposed spindle, overhead	6	-	20x20	-	70
113A015567001	Viereck-Längsaufnahme doppelt Turning Tool holder axial double Haupt-, Gegenspindel, Überkopf Main-, opposed spindle, overhead	7	-	20x20	-	70
113A015578001	Bohrstangenhalter Boring bar holder Haupt-, Gegenspindel mit IK Main-, opposed spindle with IC	8	Ø32	-	80	-
113A015581001	Verschlussdeckel Cap	-	-	-	-	-



Nakamura Ø65



Nakamura NTX
Nakamura SC-300
Nakamura SC-300 L

Nakamura SC-300 LM
Nakamura SC-300 M
Nakamura TW 20

Nakamura WT 300
Nakamura-Tome Super
NTX

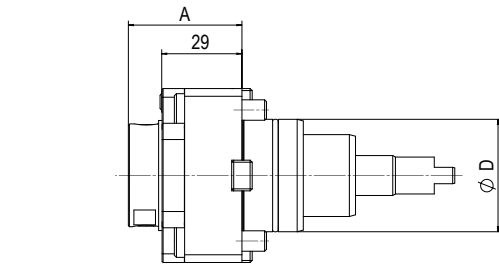

1

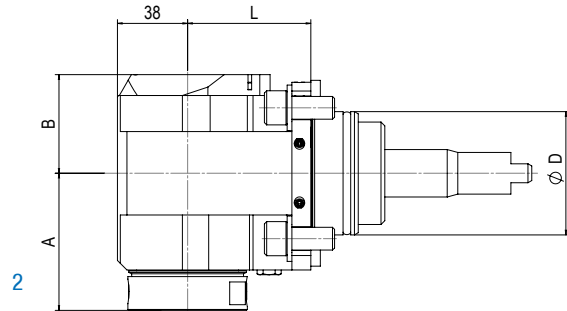

2

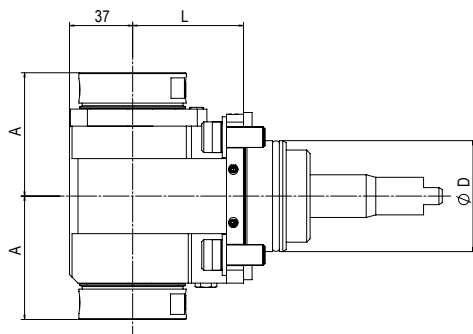

3

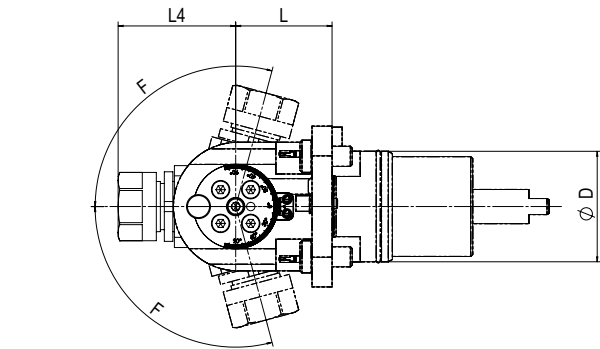

4

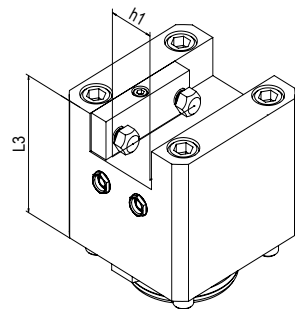

5

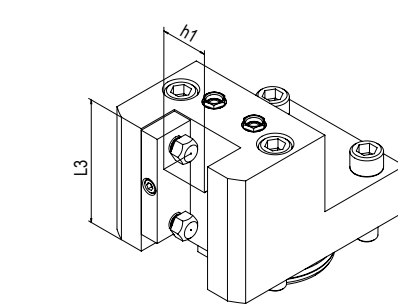

6

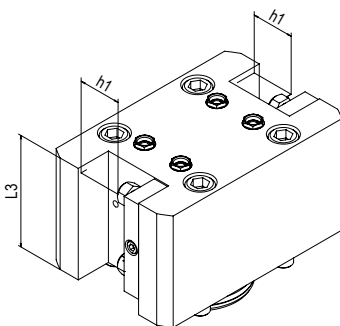

7

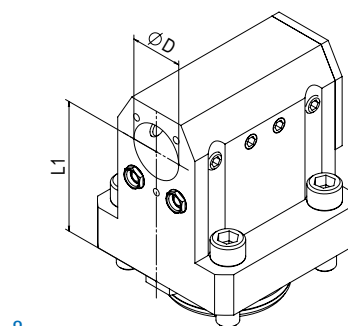

8



Angetriebene Werkzeuge | Live Tools

BENZ Solidfix® Modulares Schnellwechselsystem | Modular Quick Change System

Bestell-Nr. Order No.	Ausführung Tool style	Bild Figure	Aufnahme Tool holder	n [min ⁻¹]	Übersetzung Gear ratio	T [Nm]	EK EC	IK IC	pmax [bar]	Maße Dimensions				
										D	A	B	L	L ₄
114DA05100S4	axial	1	BENZ Solidfix® S4	6.000	1:1	50	✓	-	-	65	49	-	-	-
114EA05100S4	axial	1		6.000	1:1	50	✓	✓	50	65	49	-	-	-
114FAX05149S4D	radial	2		6.000	1:1	70	✓	-	-	65	72	50	65	-
114GAX05149S4D	radial	2		6.000	1:1	70	✓	✓	100	65	72	60	65	-
114FAX05149S42	radial Doppelspindler Double spindle	3		6.000	1:1	70	✓	-	-	65	72	-	65	-

Maß A: bis Plananlage, ohne Adapter | Dimension A: up to plane surface, without adapter

Spannzange | Collet Chuck

Bestell-Nr. Order No.	Ausführung Tool style	Bild Figure	Aufnahme Tool holder	n [min ⁻¹]	Übersetzung Gear ratio	T [Nm]	EK EC	IK IC	pmax [bar]	Maße Dimensions				
										D	A*	B	L	L ₄
114DA05100E6A	axial	1	ER 32	6.000	1:1	50	✓	-	-	65	40,1	-	-	-
114EA05100E6A	axial	1	ER 32	6.000	1:1	50	✓	✓	50	65	45,2	-	-	-
114FAX05149E6AD	radial	2	ER 32	6.000	1:1	70	✓	-	-	65	69,1	52	65	-
114GAX05149E6AD	radial	2	ER 32	6.000	1:1	70	✓	✓	100	65	74,2	60	65	-
114FAX05149E6A2	radial Doppelspindler Double spindle	3	ER 32	6.000	1:1	70	✓	-	-	65	69,1	-	65	-
114FK05138E3	schwenkbar swiveling F= ±105°	4	ER 16	8.000	1:2	8	✓	-	-	65			53	50,6

EK: externe Kühlung, IK: interne Kühlung
R: rechte Ausführung, L: linke Ausführung
Maß A*: max. Länge inkl. Spannmutter
Zubehör (ab S. 103) ist nicht im Lieferumfang enthalten.
Technische Änderungen vorbehalten.

EC: external coolant, IC: internal coolant
R: right hand design, L: left hand design
Dimension A*: max. length incl. clamping nut
Accessories (from p. 103) are not included in delivery.
We reserve the right to modify technical contents.

Statische Halter | Static tool holder

Bestell-Nr. Order No.	Ausführung Tool style	Bild Figure	Maße Dimensions			
			D ₁	h ₁	L ₁	L ₃
114A05159001	Vierkant-Queraufnahme Square locking drive radial Haupt-, Gegenspindel, Überkopf Main-, opposed spindle, overhead	5	-	25x25	-	90
114A051560001	Vierkant-Längsaufnahme Turning Tool holder axial Haupt-, Gegenspindel, Überkopf Main-, opposed spindle, overhead	6	-	25x25	-	80
114A051567001	Vierkant-Längsaufnahme doppelt Turning Tool holder axial double Haupt-, Gegenspindel, Überkopf Main-, opposed spindle, overhead	7	-	25x25	-	80
114A051578001	Bohrstangenhalter Boring bar holder Haupt-, Gegenspindel mit IK Main-, opposed spindle with IC	8	Ø32	-	80	-
114A051581001	Verschlussdeckel Cap	-	-	-	-	-





LB 2000 EX-M
 LB 2000 EX-MW
 LB 2500 EX-M
 LB 2500 EX-MW

LB 3000 EX-M
 LB 3000 EX-MW
 LB 3000 EX-MY
 LB 3000 EX-MYW

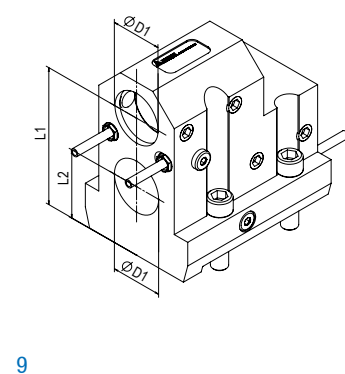
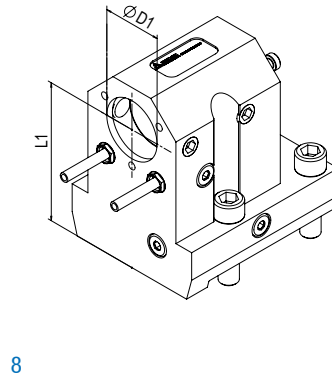
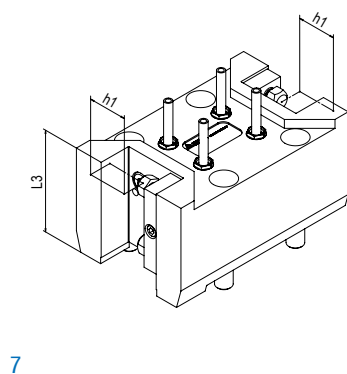
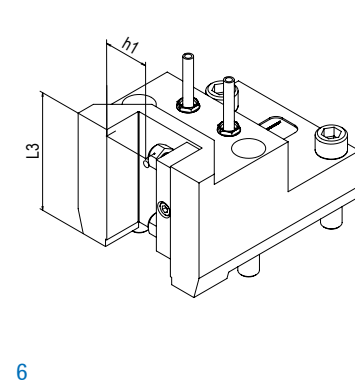
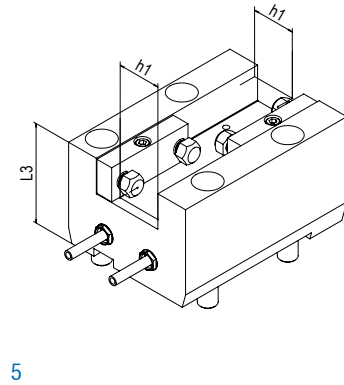
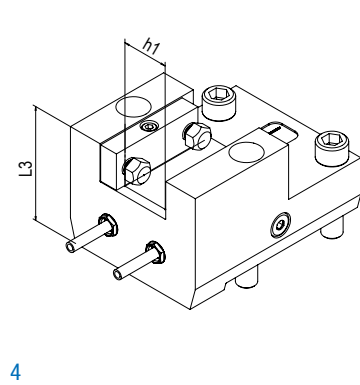
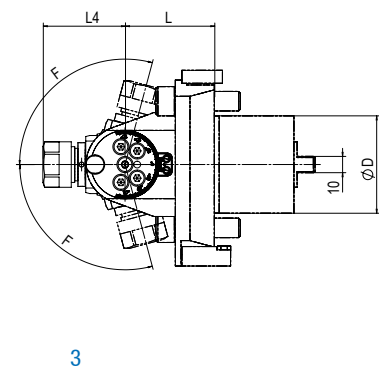
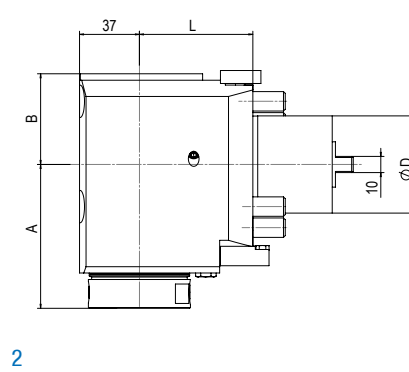
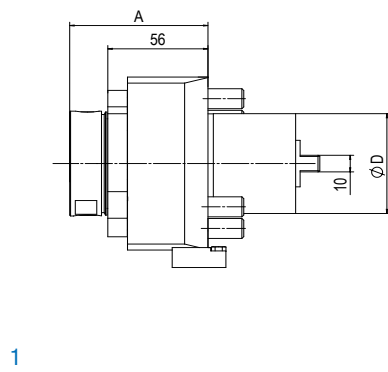

OKUMA LB 2000 - 3000 EX

Angetriebene Werkzeuge | Live Tools

BENZ Solidfix® Modulares Schnellwechselsystem | Modular Quick Change System

Bestell-Nr. Order No.	Ausführung Tool style	Bild Figure	Aufnahme Tool holder	n [min ⁻¹]	Über- setzung	T [Nm]	EK EC	IK IC	pmax [bar]	Maße Dimensions			
										D	A*	B	L
114DA09841S4	axial	1	BENZ Solidfix® S4	6.000	1:1	70	✓	-	-	60	77	-	-
114EA09841S4	axial	1		6.000	1:1	70	✓	✓	50	60	77	-	-
114FAX09849S4D-70	radial	2		6.000	1:1	70	✓	-	-	60	89	56	70
114GAX09849S4D-70	radial	2		6.000	1:1	70	✓	✓	100	60	89	58	70

Maß A: bis Plananlage, ohne Adapter | Dimension A: up to plane surface, without adapter

Spannzange | Collet Chuck

Bestell-Nr. Order No.	Ausführung Tool style	Bild Figure	Aufnahme Tool holder	n [min ⁻¹]	Über- setzung Gear ratio	T [Nm]	EK EC	IK IC	pmax [bar]	Maße Dimensions				
										D	A*	B	L	L ₄
114DA09841E6A	axial	1	ER32	6.000	1:1	70	✓	-	-	60	67,1	-	-	
114EA09841E6A	axial	1	ER32	6.000	1:1	70	✓	✓	50	60	72,2	-	-	
114FAX09849E6AD-70	radial	2	ER32	6.000	1:1	70	✓	-	-	60	86,1	56	70	
114GAX09849E6AD-70	radial	2	ER32	6.000	1:1	70	✓	✓	100	60	91,2	58	70	
114FK09838E3	schwenkbar swiveling F= ±105°	3	ER16	8.000	1:2	8	✓	-	-	60			53	50,6

EK: externe Kühlung, IK: interne Kühlung
Maß A*: max. Länge inkl. Spannmutter
Zubehör (ab S. 103) ist nicht im Lieferumfang enthalten.
Technische Änderungen vorbehalten.

EC: external coolant, IC: internal coolant
Dimension A*: max. length incl. clamping nut
Accessories (from p. 103) are not included in delivery.
We reserve the right to modify technical contents.

OKUMA
BMT-Schaft
BMT-Shank

Statische Halter | Static tool holder

Bestell-Nr. Order No.	Ausführung Tool style	Bild Figure	Maße Dimensions				
			D ₁	h ₁	L ₁	L ₂	L ₃
114A098559001	Vierkant-Queraufnahme Square locking drive radial Haupt-, Gegenspindel, Überkopf Main-, opposed spindle, overhead	4	-	25x25	-	-	70
114A098587001	Vierkant-Queraufnahme doppelt Square locking drive radial double Haupt-, Gegenspindel, Überkopf Main-, opposed spindle, overhead	5	-	25x25	-	-	70
114A098560001	Vierkant-Längsaufnahme Turning Tool holder axial Haupt-, Gegenspindel, Überkopf Main-, opposed spindle, overhead	6	-	25x25	-	-	75
114A098567001	Vierkant-Längsaufnahme doppelt Turning Tool holder axial double Haupt-, Gegenspindel, Überkopf Main-, opposed spindle, overhead	7	-	25x25	-	-	75
114A098578001	Bohrstangenhalter Boring bar holder Haupt-, Gegenspindel mit IK Main-, opposed spindle with IC	8	Ø40	-	90	-	-
114A098579001	Bohrstangenhalter doppelt Boring bar holder double Haupt-, Gegenspindel Main-, opposed spindle	9	Ø40	-	105	50	-
114A098581001	Verschlussdeckel Cap	-	-	-	-	-	-