

# Mori Seiki NL / NT Ø60

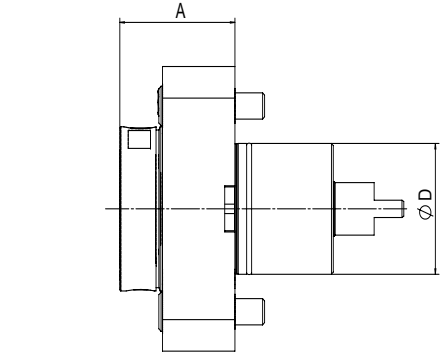

- NL 1500
- NL 2000
- NL 2500
- NL 3000
- NT 4250



1

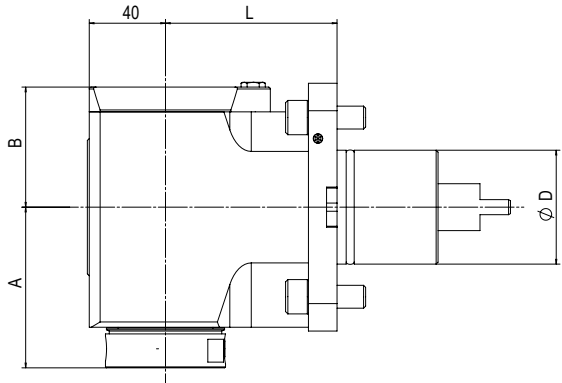

2

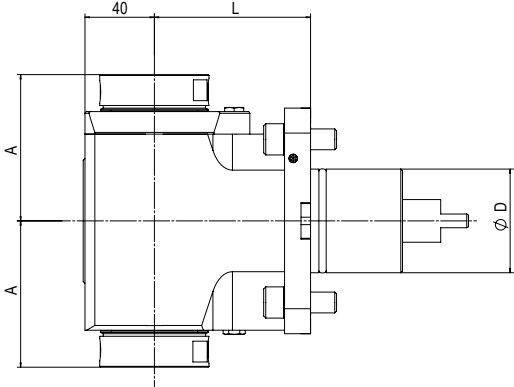

3

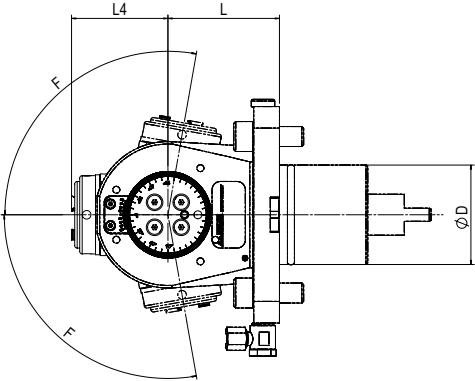

4

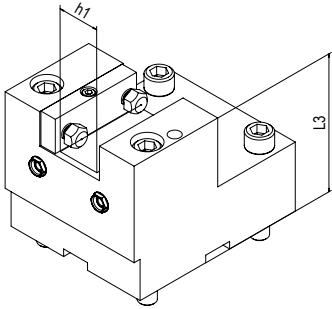

5

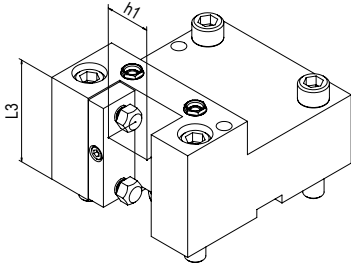

6

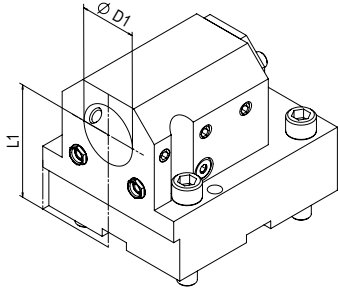

7



## Angetriebene Werkzeuge | Live Tools

### BENZ Solidfix® Modulares Schnellwechselsystem | Modular Quick Change System

Bestell-Nr. Order No.	Ausführung Tool style	Bild Figure	Aufnahme Tool holder	n [min <sup>-1</sup> ]	Übersetzung Gear ratio	T [Nm]	EK EC	IK IC	pmax [bar]	Maße   Dimensions				
										D	A	B	L	L <sub>4</sub>
115DA03500S5	axial	1	BENZ Solidfix® S5	6.000	1:1	100	✓	-	-	60	62	-	-	-
115EA03500S5	axial	1		6.000	1:1	100	✓	✓	50	60	62	-	-	-
115FAX03559S5D	radial	2		6.000	1:1	150	✓	-	-	60	86	63	90	-
115GAX03559S5D	radial	2		6.000	1:1	150	✓	✓	100	60	86	70	90	-
115FAX03559S52	Doppelspindler Double spindle	3		6.000	1:1	150	✓	-	-	60	86	-	90	-

Maß A: bis Plananlage, ohne Adapter | Dimension A: up to plane surface, without adapter

Mori Seiki

### Werkzeuge für High Speed Revolver auf Anfrage Live tools for high speed turret on demand

### Spannzange | Collet Chuck

Bestell-Nr. Order No.	Ausführung Tool style	Bild Figure	Aufnahme Tool holder	n [min <sup>-1</sup> ]	Übersetzung Gear ratio	T [Nm]	EK EC	IK IC	pmax [bar]	Maße   Dimensions				
										D	A*	B	L	L <sub>4</sub>
115DA03500E7A	axial	1	ER40	6.000	1:1	100	✓	-	-	60	67	-	-	-
115EA03500E7A	axial	1	ER40	6.000	1:1	100	✓	✓	50	60	71,9	-	-	-
115FAX03559E7AD	radial	2	ER40	6.000	1:1	150	✓	-	-	60	81,5	63	-	-
115GAX03559E7AD	radial	2	ER40	6.000	1:1	150	✓	✓	100	60	86,4	70	-	-
115FAX03559E7A2	radial Doppelspindler Double spindle	3	ER40	6.000	1:1	150	✓	-	-	60	81,5	-	-	-
115FDX03549E5A	schwenkbar swiveling	4	ER25	6.000	1:0,82	32	✓	-	-	60	-	-	54,3	70,6
115GDX03549E5A	F= ±100°	4	ER25	6.000	1:0,82	32	✓	✓	50	60	-	-	54,3	75,7

EK: externe Kühlung, IK: interne Kühlung  
R: rechte Ausführung, L: linke Ausführung  
Maß A\*: max. Länge inkl. Spannmutter  
Zubehör (ab S. 103) ist nicht im Lieferumfang enthalten.  
Technische Änderungen vorbehalten.

R: right hand design, L: left hand design  
EC: external coolant, IC: internal coolant  
Dimension A\*: max. length incl. clamping nut  
Accessories (from p. 103) are not included in delivery.  
We reserve the right to modify technical contents.

### Statische Halter | Static tool holder

Bestell-Nr. Order No.	Ausführung Tool style	Bild Figure	Maße   Dimensions			
			D <sub>1</sub>	h <sub>1</sub>	L <sub>1</sub>	L <sub>3</sub>
115A03559001	Vierkant-Queraufnahme   Square locking drive radial Haupt-, Gegenspindel, Überkopf   Main-, opposed spindle, overhead	5	-	25x25	-	100
115A035560002	Vierkant-Längsaufnahme   Turning Tool holder axial Haupt-, Gegenspindel, Überkopf   Main-, opposed spindle, overhead	6	-	25x25	-	70
115A035578002	Bohrstangenhalter   Boring bar holder Haupt-, Gegenspindel mit IK   Main-, opposed spindle with IC	7	Ø40	-	80	-
115A035581001	Verschlussdeckel   Cap	-	-	-	-	-

# Mori Seiki NZ / NT / NTX Ø40



NZ 1500  
 NZ 2000  
 NT 1000

NT 2000  
 NTX 1000  
 NTX 2000

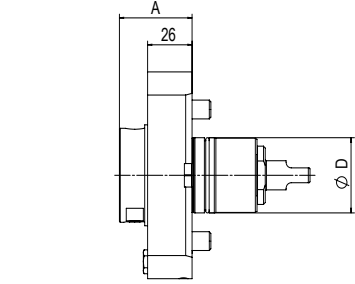

1

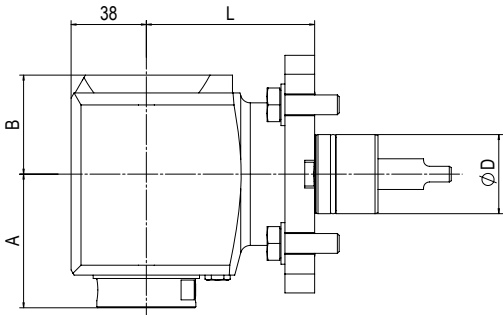

2

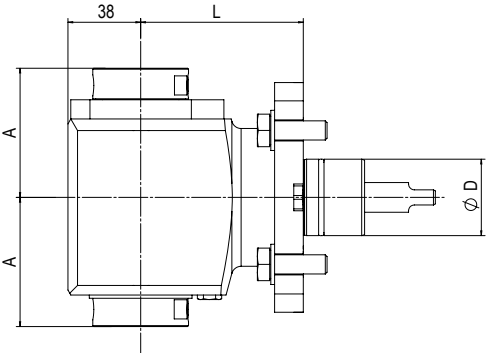

3

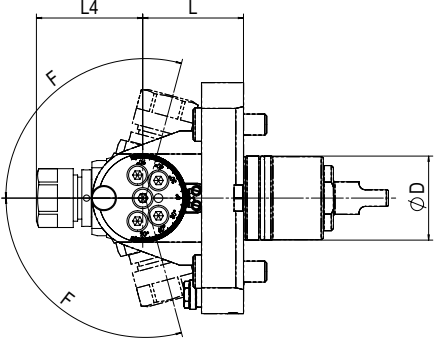

4

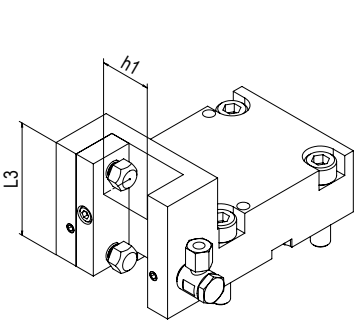

5

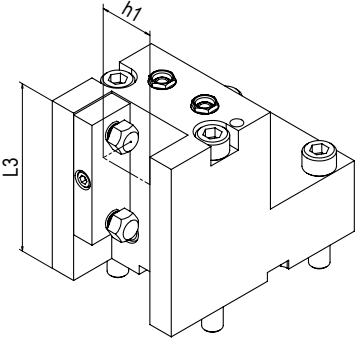

6

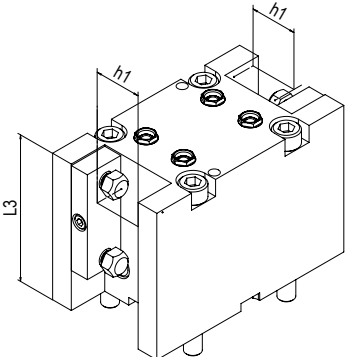

7

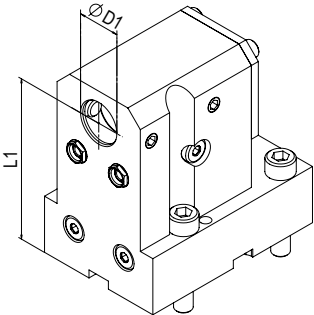

8

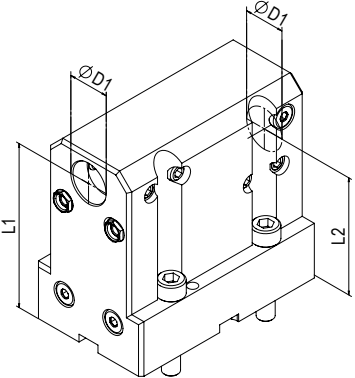

9



## Angetriebene Werkzeuge | Live Tools

**BENZ Solidfix®** Modulares Schnellwechselsystem | Modular Quick Change System

Bestell-Nr. Order No.	Ausführung Tool style	Bild Figure	Aufnahme Tool holder	n [min <sup>-1</sup> ]	Übersetzung Gear ratio	T [Nm]	EK EC	IK IC	pmax [bar]	Maße   Dimensions			
										D	A	B	L
113DA05300S3	axial	1	BENZ Solidfix® S3	8.000	1:1	50	✓	-	-	40	45	-	-
113EA05300S3	axial	1		8.000	1:1	50	✓	✓	50	40	59	-	-
113FAX05339S3D	radial	2		8.000	1:1	30	✓	-	-	40	56	50	85
113GAX05339S3D	radial	2		8.000	1:1	30	✓	✓	100	40	56	60	85
113FAX05339S32	radial Doppelspindel Double spindle	3		8.000	1:1	30	✓	-	-	40	56	-	85

Maß A: bis Plananlage, ohne Adapter | Dimension A: up to plane surface, without adapter

Mori Seiki

**Werkzeuge für High Speed Revolver auf Anfrage**  
Live tools for high speed turret on demand

## Spannzange | Collet Chuck

Bestell-Nr. Order No.	Ausführung Tool style	Bild Figure	Aufnahme Tool holder	n [min <sup>-1</sup> ]	Über- setzung Gear ratio	T [Nm]	EK EC	IK IC	pmax [bar]	Maße   Dimensions				
										D	A*	B	L	L <sub>4</sub>
113DA05300E5A	axial	1	ER 25	8.000	1:1	50	✓	-	-	40	37,9	-	-	
113EA05300E5A	axial	1	ER 25	8.000	1:1	50	✓	✓	50	40	62,4	-	-	
113FAX05339E5AD	radial	2	ER 25	8.000	1:1	30	✓	-	-	40	56,9	50	85	
113GAX05339E5AD	radial	2	ER 25	8.000	1:1	30	✓	✓	100	40	61,9	60	85	
113FAX05339E5A2	radial Doppelspindel Double spindle	3	ER 25	8.000	1:1	30	✓	-	-	40	56,9	-	85	
113FK05338E3	schwenkbar swiveling F= ±105°	4	ER 16	8.000	1:2	8	✓	-	-	40			53	50,6

EK: externe Kühlung, IK: interne Kühlung  
Maß A\*: max. Länge inkl. Spannmutter  
Zubehör (ab S. 103) ist nicht im Lieferumfang enthalten.  
Technische Änderungen vorbehalten.

EC: external coolant, IC: internal coolant  
Dimension A\*: max. length incl. clamping nut  
Accessories (from p. 103) are not included in delivery.  
We reserve the right to modify technical contents.

## Statische Halter | Static tool holder

Bestell-Nr. Order No.	Ausführung Tool style	Bild Figure	Maße   Dimensions				
			D <sub>1</sub>	h <sub>1</sub>	L <sub>1</sub>	L <sub>2</sub>	L <sub>3</sub>
113A053582001	Abstechhalter   Infeed Toolholder	5	-	25x25	-	-	68
113A053560001	Vierkant-Längsaufnahme   Turning Tool holder axial	6	-	20x20	-	-	95
113A053560002	Haupt-, Gegenspindel, Überkopf   Main-, opposed spindle, overhead	6	-	25x25	-	-	95
113A053567001	Vierkant-Längsaufnahme doppelt Turning Tool holder axial double	7	-	20x20	-	-	95
113A053567002	Haupt-, Gegenspindel, Überkopf   Main-, opposed spindle, overhead	7	-	25x25	-	-	95
113A053578001	Bohrstangenhalter   Boring bar holder	8	Ø32	-	100	-	-
113A053578002	Haupt-, Gegenspindel mit IK   Main-, opposed spindle with IC	8	Ø25	-	100	-	-
113A053579001	Bohrstangenhalter doppelt   Boring bar holder double Haupt-, Gegenspindel mit IK   Main-, opposed spindle with IC	9	Ø25	-	105	75	-
113A053581001	Verschlussdeckel   Cap	-	-	-	-	-	-